



# **KES Enviro TRUFLOW: Operation and Maintenance Manual**

---

Spring Air Systems Inc., Oakville, Ontario  
Phone (866) 875-4505, Fax (905) 338-0179, [info@springairsystems.com](mailto:info@springairsystems.com)  
[www.springairsystems.com](http://www.springairsystems.com)

May 2008

# KES ENVIRO TRUFLOW OPERATION AND MAINTENANCE MANUAL

## Table of Contents

Introduction	1
The System	1
Control Circuit	3
KES Truflow Touchscreen	4
Control system	7
Variable frequency drive	8
User Setup	9
User setup screen button functions	12
The diagnostic screen	16
The report screen	17
Maxflow	19
Odor spray system	21
Where to purchase filters	24
Replacement filter equivalent	24
When to change the KES filters	25
Troubleshooting	27
KES maintenance schedule	29
Appendix A: PXR3 Micro-controller: Factory setup	32
Appendix B: Factory drive terminal schematic	34
Appendix C: Hazardous wiring	36
Appendix D: Good wiring practice	37
Appendix E: Grounding	38
Appendix F: Starting the drive	39
Appendix G: Accessing the drive program menu	40
Appendix H: Programming the drive parameters	42
Appendix I: Drive factory reset	50
Appendix J: Troubleshooting and drive fault display	52
Appendix K: Truflow factory wiring	57
Appendix L: Truflow initial setup	58
Appendix M: LV10 Factory Wiring	58
	79



# KES ENVIRO TRUFLOW OPERATION AND MAINTENANCE MANUAL

## INTRODUCTION

Thank you for purchasing a Spring Air Systems commercial kitchen ventilation product. Please read the complete "KES Enviro Operation and Maintenance TrufLOW Manual" prior to installation, commissioning or operating a KES unit.

The SPRING AIR SYSTEMS INC. kitchen Enviro system (KES), Exhaust Cleaning Assembly for Kitchen Exhaust Duct, "Enviro Unit" is ULC and UL listed for use in a commercial kitchen exhaust system. KES units are available in sizes ranging from 1,000 CFM to 40,000 CFM for indoor or outdoor applications.

The primary function of a KES Enviro unit is to filter the grease, lint and dust particles and remove the odor from the exhaust air.

The Underwriters Laboratories Inc. (UL) and Underwriters' Laboratories of Canada Limited (ULC) listings allow the kitchen exhaust air to be discharge to atmosphere at low levels.

**Prior to any installation the installer must seek approval from the authorities having jurisdiction.**



KES-ISH Enviro Filter Box  
Figure 1



KESF Enviro Fan Box  
Figure 2

## THE SYSTEM

The grease-laden air rises from the cooking equipment into a UL or ULC exhaust hood. The exhaust hood removes some of the airborne grease particulate. Typically most micron and submicron particles escape into the exhaust ductwork. The exhaust ducting is connected from the hood to the inlet of the KES Enviro unit. This exhaust ductwork must be supplied and installed in accordance with the NFPA-96 code.

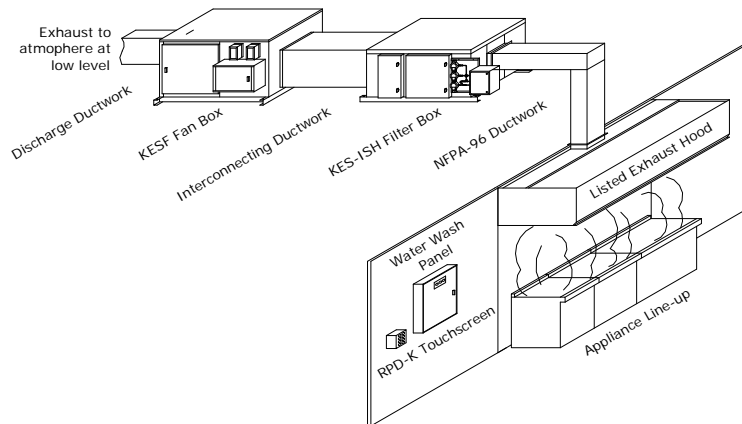

KES System Schematic  
Figure 3

Once through the particulate filter sections the exhaust air enters the optional odor removal section. The odor section is only required when discharging cooking smells may be offensive. This section consists of two optional odor removal systems.

1. Odor Cells filled with activated alumina impregnated with potassium permanganate. The odor is controlled through a combination of sorption and the chemical modification of the gaseous contaminates. The odor media is non-toxic and non-flammable.
2. Odor spray solution. The odor is control by spraying an odor reducer into the exhaust air stream intermittently during the operation of the cooking systems. The odor spray unit is normally located mounted on the KESF fan section. The cabinet includes an air compressor, atomizing air nozzle and piping and odor spray container.



*Odor Spray components  
Figure 4*

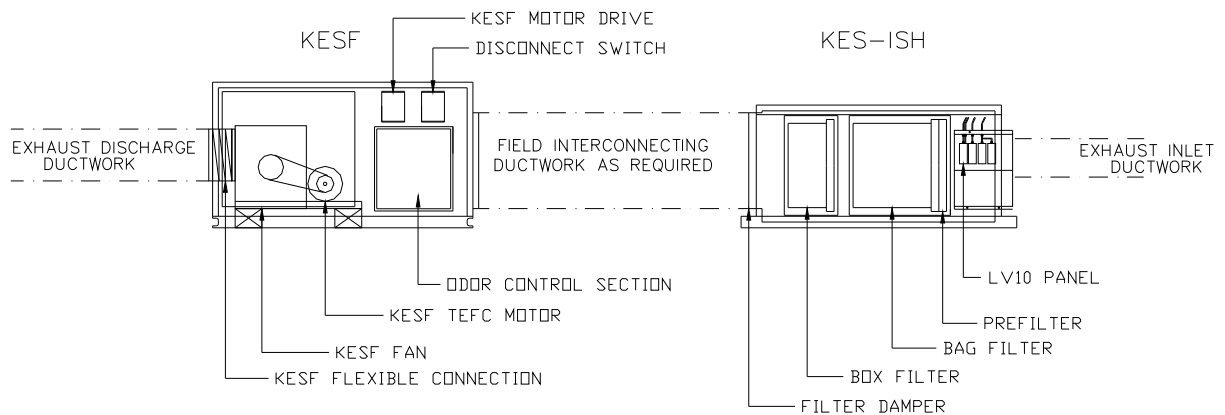

*KES-ISH and KESF Enviro components  
Figure 5*

The exhaust air is discharged from the KES unit through a single width, single inlet (SWSI) or double width, double inlet (DWDI) exhaust fan. The discharge ductwork transfers the exhaust air outdoors.

# CONTROL CIRCUIT

## **Filter Clogged:**

During normal operation of the KES unit three-filter stages collect grease, dust, and lint particulate. The type of cooking equipment and the hours of operation determines the useful life of the individual filters.

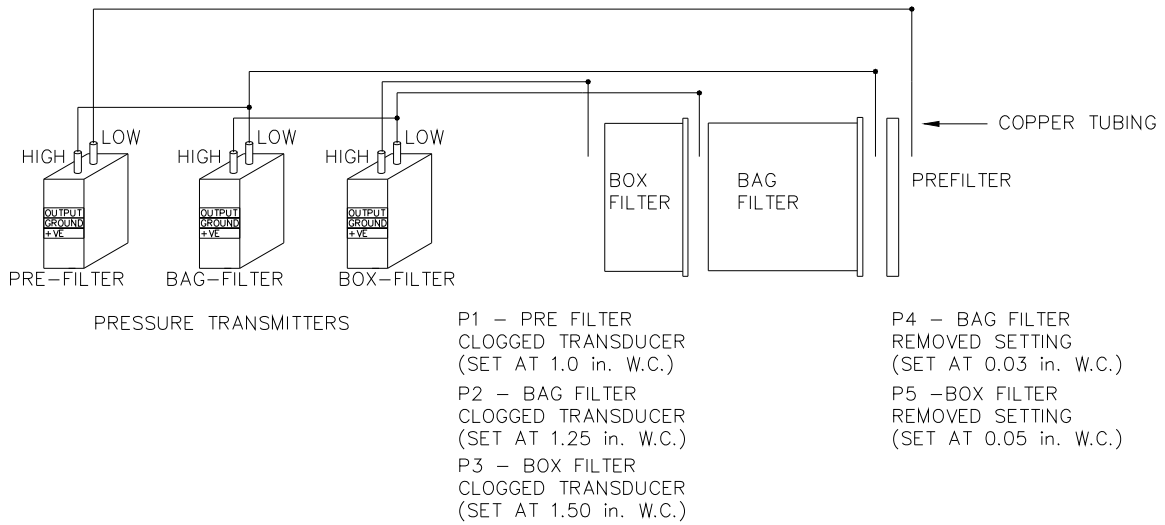

*Pressure Transmitter Locations  
Figure 6*



*Box Filter probes as viewed  
from discharge  
Figure 7*

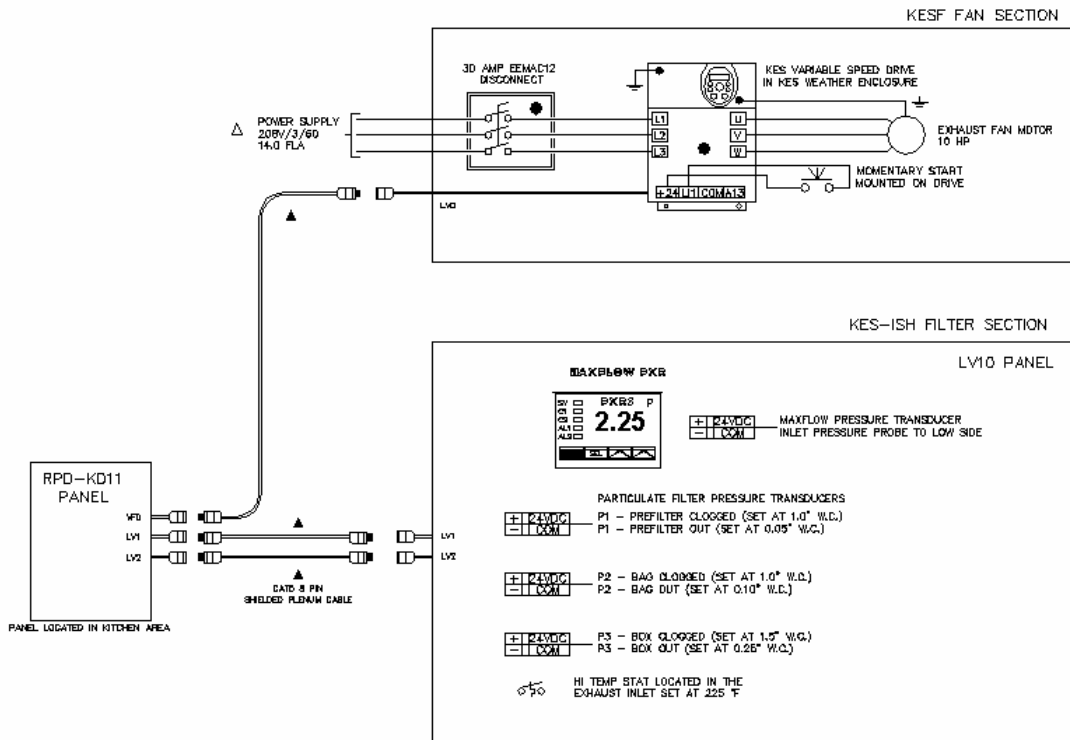

Typical Truflow indoor KES, Drive and, LV10 wiring schematic  
Figure 8

Pressure transducers determine when the filters are completely dirty and must be replaced. As the filter reaches the grease loading capacity the static pressure across each filter increases. When the maximum static pressure is reached the transducer activated an alarm on the Truflow screen.. The exhaust fan shuts off, the clogged alarm screen appears and the override pushbutton appears (The Truflow screen indicates which stage of filters has clogged; PREFILTER, BAG FILTER, or BOX FILTER.)

### KES Truflow Touch Screen

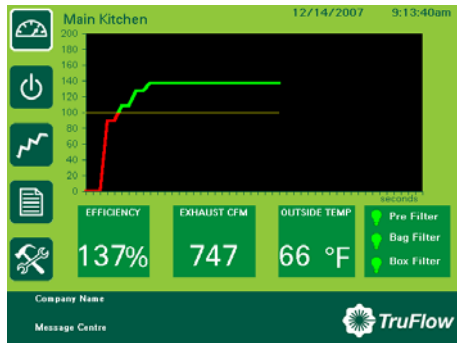

RPD-KD located in kitchen  
indicating all filters green and  
status OK.  
Figure 9

- Pre Filter
- Bag Filter
- Box Filter

When a Spring Air Systems commercial kitchen Enviro (KES) unit is installed in the exhaust ductwork in conjunction with the kitchen exhaust hoods the DASHBOARD incorporates a Pre Filter, Bag Filter and Box Filter status button. The KES unit is designed to remove grease and particulates from the kitchen exhaust air in accordance to the UL1978 standard for commercial kitchen exhaust. The grease and particulates are removed with three particulate filters located in the KES unit. These filters will clog with particulate and grease and must be replaced from time to time. The Enviro Status button informs the user the condition of each of the three filters. Green indicates the filter is OK. Yellow indicates the filter is nearing the end of the filters useful life and will require replacing shortly. Red indicates the filter is about to clog and must be replaced as soon as possible.

## Filter Annunciation



Press the Enviro Status button on the DASHBOARD and the Enviro Status screen appears

*Enviro filter status screen shown on kitchen mounted Truflow panel  
Figure 10*



The first bar indicates the amount that the Pre Filter that has been used. The yellow area is the used portion of the Pre Filter and the green area above the yellow area is the portion left. In this case the Pre Filter has about 20% usage left. The 0.61 value is the pressure drop in inches W.C. across the filter.



The second bar indicates the amount of the Bag Filter that has been used. The bright green area is the used portion of the Bag Filter and the green area above the bright green area is the portion left. In this case the Bag Filter has about 80% usage left. The 0.31 value is the actual pressure drop in inches W.C. across the filter.



The third bar indicates the amount the Box Filter that has been used. The bright green area is the used portion of the Box Filter and the green area above the bright green area is the portion left. In this case the Box Filter has about 90% usage left. The 0.21 value is the actual pressure drop in inches W.C. across the filter.

A clogged filter must be replaced and the system reset to resume normal operation. If this condition occurs during normally operating hours press the OVERRIDE button on the Truflow screen and the fan will come back on. The system can run in the OVERRIDE position for about 4 hours. If the system runs longer than 4 hours the fan will shut down. The filters must be changed and the system reset. It is recommended that the filters be changed prior to the filter clogged light energizing. A filter usage chart is attached to record when the filters are being changed. Using this chart a regular maintenance schedule can be set up to ensure constant uninterrupted operation of the commercial kitchen.

### **Filter Removed:**

Should the bag or box filters be removed during normal operation the KES unit is automatically shutdown. A pressure transducer measuring static pressure across the bag filters and box filters monitors a minimum pressure drop of 0.02" W.C. When the filter is removed the pressure differential falls and the pressure switch is activated. The exhaust fan shuts off, the alarm screen appears and the Diagnostic Screen will indicate "FILTER REMOVED/LOW EXHAUST. To resume normal operation the filter must be replaced and the system reset.

### **High Temperature:**

In the event of a high temperature in the inlet to the KES-ISH filter unit a high temperature stat located at the inlet of the KES-ISH filter section is activated. When the exhaust air reaches 160 F the high temperature stat is energized. The exhaust fan shuts off, the alarm screen appears and the Diagnostic Screen will indicate "High temperature in the KES". Should the KES exhaust temperature continue to rise the fusible link melts in the KES-ISH filter section discharge and closes the fire damper in the exhaust. This fire damper is always located between the fan and filter section. The fire damper fusible link is rated at 165 F. Shut off all cooking equipment and notify the fire department. To resume normal operation, replace the fusible link and reset the system. An authorized SPRING AIR SYSTEM INC. service technician should be called to inspect the unit.

### **System Reset:**

After any alarm screen annunciation the system must be reset.



When an error occurs the screen will change to red with a yellow exclamation mark.

Touch the screen anywhere and the diagnostic screen appears.

The screen displays the latest error message including the date, time, state and whether the error has been acknowledged. Most errors are self explanatory.



Press this button for additional explanation. When available a popup screen appears with additional information.

*Truflow Alarm screen  
Figure 11*

Whenever there is a COMM PORT or COMM error or fault, the Clear Error On Drive button must be pressed after the faults has been corrected to resume normal operation.

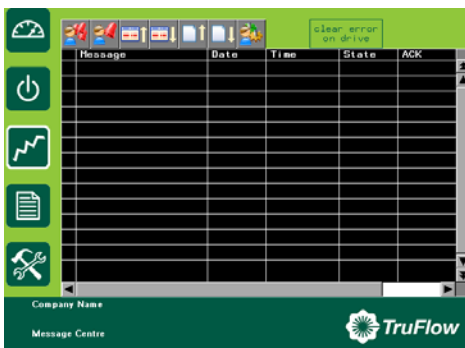

*Truflow diagnostic screen  
Figure 12*



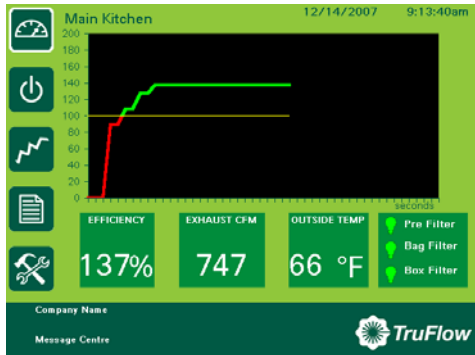

energy consumption measured against a reduction goal. The Dashboard tells the kitchen staff whether the system is exceeding the goal or not.

*Touchscreen Dashboard  
Figure 13*

## CONTROL SYSTEM

### a. Dashboard



The Touchscreen is the heart of the TruFlow, integrating the J-Couples and VSD to provide a complete commercial kitchen Energy Management Controller. The

Touchscreen includes five functional screens: Dashboard, System Control, Alarm Status, Reports and Setup & Diagnostics.

Press the Dashboard icon to view the Dashboard. The Dashboard includes a graph that represents the energy use throughout the day. The graph provides

EFFICIENCY, Exhaust CFM, outdoor temperature is also displayed. The outdoor temperature measurement allows for real-time energy savings reports directly from TruFlow!



*Touchscreen System Control  
Figure 14*

### b. System Control



The System Control displays components of all exhaust systems controlled by TruFlow including Hood lights, Fan on/off switch, Summer/winter switch, and Override timer.

Message	Date	Time	State	ACK
Alarm 1: No P4R	07/06/22	18:00:25	ACTIVE	
Alarm 2: HI Temp	07/06/22	18:00:25	ACTIVE	

*Alarm Condition Screen  
Figure 15*

### c. Alarm Status



The Alarm conditions are displayed for all systems controlled by TruFlow. Touch the single bell icon to clear selected alarm.

Touch multi-bell icon to clear all alarms

This action does not FIX the problem it simply records that an alarm or alarms have been acknowledged. Service Company must still be called!



Touchscreen Reports  
Figure 16

#### e. Reports



TruFlow can record a full year of data. The standard reports provided are seen on the Report screen. % Time Exceeding Goal is the key energy management report.

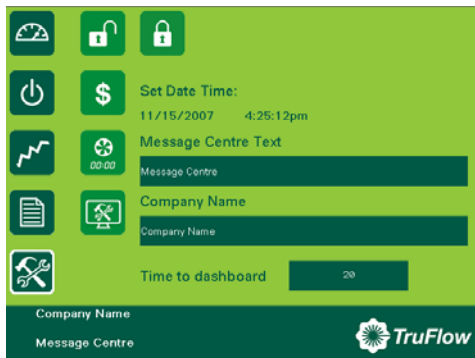

Touchscreen Setup  
Figure 17

#### f. Setup & Diagnostics



The main system setup display allows entry of reduction goal, primary message center text, and company or restaurant name.

The power of TruFlow lies in the setting of an energy reduction goal. The goal represents a target % reduction of past utility costs (hourly or monthly rate). **Goal can be reset at any time to maximize energy efficiency and savings!**

Gas and electricity costs can be entered at any time as monthly or hourly rates. TruFlow can measure gas in joules or therms by selecting Imperial or Metric Units. User may set daily or weekly operating times. Diagnostics screen provides comprehensive service screen to quickly diagnose problems. The screen can be accessed via Internet for remote service by Spring Air directly or Authorized Service Technician.

## Variable Frequency Drives (VFD)

The variable speed drives for the exhaust and/or supply fan may be located in a stainless steel enclosure adjacent to the Touchscreen panel or elsewhere in the building.

- When the makeup air unit is direct gas fire (like the Spring Air Systems SAT unit) the supply drive may be located in the makeup air unit control panel or with the exhaust fan drive(s) in a separate enclosure. (SV Type)
- When the make up air unit is indirect gas fired (like the Spring Air SFT unit) the supply drive is not required. The Touchscreen panel sends a 4-20milliamp signal through a CAT5 cable to the makeup air unit modulating bypass damper. (SC Type)



VSD front  
Figure 18

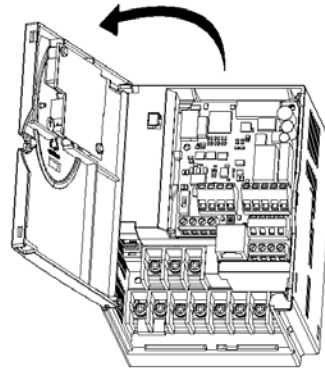

VSD open front  
Figure 19

A CAT5 cable is connected to the KESF fan drive in series from the Touchscreen panel. The first cable connects from the Touchscreen to the first KESF fan drive “Y” connector. The 2<sup>nd</sup> KESF fan drive cable connects from the first drive “Y” connector to the 2<sup>nd</sup> drive “Y” connector. Each drive is connected in series. When the Touchscreen is initially activated the communication software starts all the exhaust and/or supply drive at 100% capacity for 20 seconds for each KES kitchen. After the initial 20 seconds the exhaust and/or supply drives ramp up or down depending on the signal from the J-couple(s). As the exhaust volume increases and decreases the supply volume increases and decreases in unison to maximize energy savings. The supply unit motorized damper end switch can also be interlocked to the Touchscreen such that the end switch must close to start the supply fan drive operation. The drive changes the AC frequency to the exhaust motor between 18Hz and 60Hz.

## User Setup

### Login

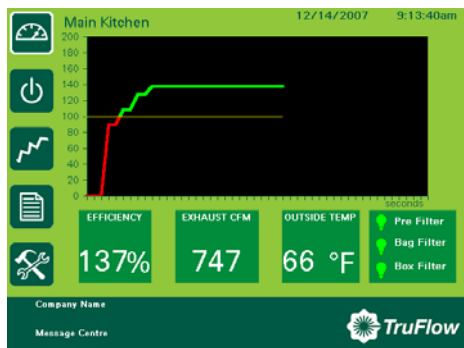

Touchscreen Dashboard  
Figure 20



From the Dashboard screen press the Setup icon.

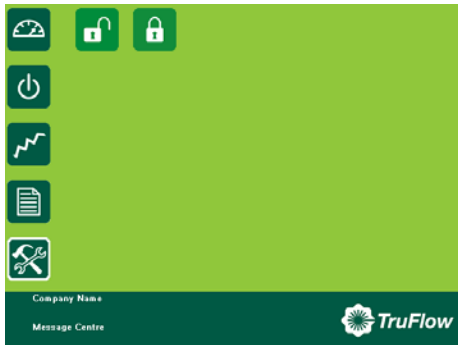

Press the Login icon.

*Touchscreen Login screen  
Figure 21*

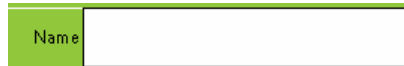

Press the white area beside Name.



A typewrite pad appears. Enter the login name. The login name is case sensitive. The CAPS key is on

automatically. If you do not know your login name and password call Spring Air Systems. After the login Name is complete press the Enter key. The screen will return to the Login screen.

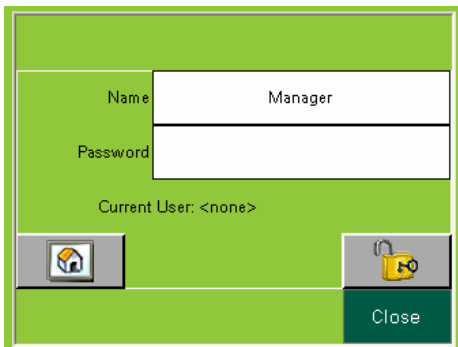

Press the white area beside Password. The keyboard screen appears again. Type the login password. The password is also case sensitive. When the login Password is complete press the enter key. The screen will return to the Login screen.



Press the UNLOCK icon. Press the word Close to close the login box. You have completed the login.

*Touchscreen password screens  
Figure 22*

### Logout

After you have completed the user setup, ensure that you logout of the setup so that your setup entries are saved and cannot be changed accidentally by the kitchen staff.



Press the Setup screen button.

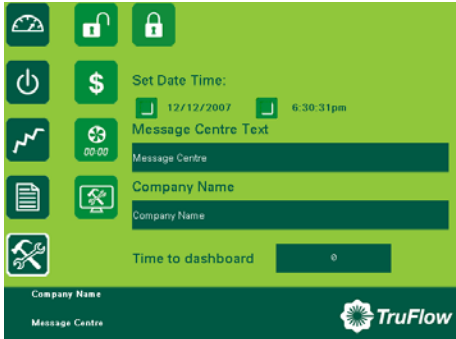

Press the lock.

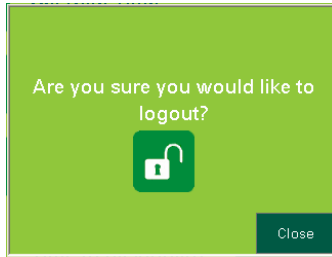

Press the lock again. You are now logged out. Once you have logged out there is no longer access to any setup screen. All settings are saved until you login again and change them.

Touchscreen setup screens  
Figure 23

### User Setup Screen Overview

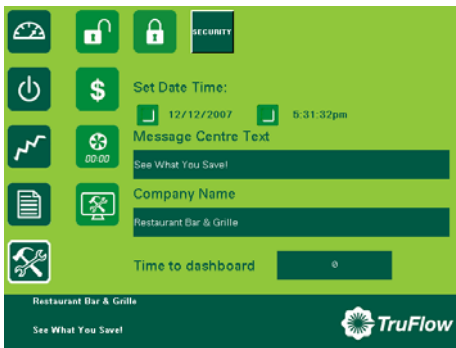

Press to set Date and Time on Dashboard



Press to setup annual energy savings goals for TruFlow Kitchen Operation



Press to setup automatic Kitchen open and closed operating times.



Press to change message on bottom of Dashboard screen.



Press to change company name on top of Dashboard screen.



Press to change the time before TruFlow switches from any screen back to Dashboard screen.



Press Security button to add or remove users and their passwords.



Press Setup icon to view current drive information.

# User Setup Screen Button Functions

## Setting Date and Time



Press the box beside the date and time to change the date and time. A popup screen appears. Enter the new date and/or time.

## Energy Goal Reduction Setup



Press the dollar icon and the Goal Reduction Screen appears.



Press the Reduction Goal box to select a goal reduction for the Kitchen operated by the TruFlow panel.



A Reduction Goal keyboard appears. Enter the Reduction Goal by touching the keypad and press the Enter button.



**Gas Cost:** Press the Gas Cost box and enter the cost of energy for the kitchen based on \$/thm (\$/1,000,0000 btu's) using the pop up key board.

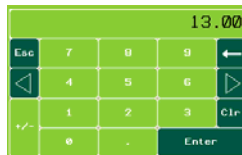

A Gas Cost keyboard appears. Enter the Gas cost by touching the keypad and press the Enter button.



**Electricity Cost:** Press the Electricity Cost box and enter the cost of electricity for the kitchen based \$/KWH using the pop up key board.

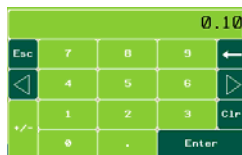

An Electricity Cost keyboard appears. Enter the Electricity cost by touching the keypad and press the Enter button



**Demand Electricity Cost:** If the commercial kitchen operation pays extra for electricity during peak periods of the day select the Demand Electrical button.



Enter the higher electrical rate at peak periods in the Demand Electricity cost box. Press the 0.00 in the box and a Demand Electrical Cost keypad appears. Enter Demand Electrical cost by touching the keypad and press the Enter button

**Demand Electricity Cost:**



Enter of the time of day the Peak electrical rate starts.



Enter the time of day the Peak electrical rate ends

For calculation of the energy cost select whether the kitchen is air conditioned with DX or chilled water cooling. The cost of cooling the fresh air into the kitchen will be added to the kitchen energy during the summer months.



**DX Cooling Option:**

No DX or chilled water cooling of kitchen fresh air.



Press the Button when there is DX or Chilled Water cooling of kitchen fresh air.



Press the Setup button again to return to the primary set up screen

**Time to Dashboard:**



Press the 20 in the Time to dashboard box to select the number of seconds before the TruFlow switches back to the DASHBOARD screen. If you want the TruFlow to remain on the last screen viewed set the number to 0.

**Setting the automatic Opening and Closing Times:**

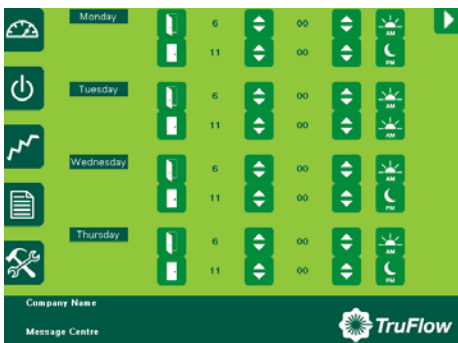

Select the time for the kitchen exhaust system to start for Monday through Sunday.



Select the time for the kitchen exhaust system to stop for Monday through Sunday.



Press the next page button to set Friday, Saturday and Sunday.

If the Kitchen does not operate during any day, make the start and stop time the same and the kitchen exhaust system will not operate that day.

### Entering the Message Center Text:

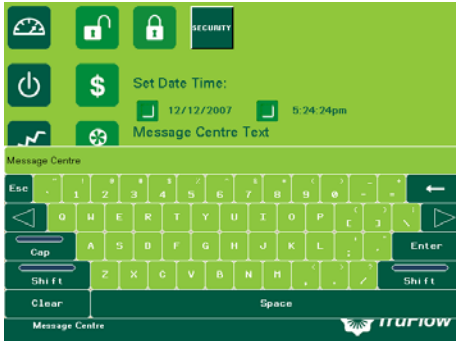

#### Message Centre Text

Message Centre

Press the words Message Center to open the Message Center Text keyboard. Using this keyboard, enter the daily message for the kitchen staff. When you have completed the message press Enter.

### Entering the Company Name:

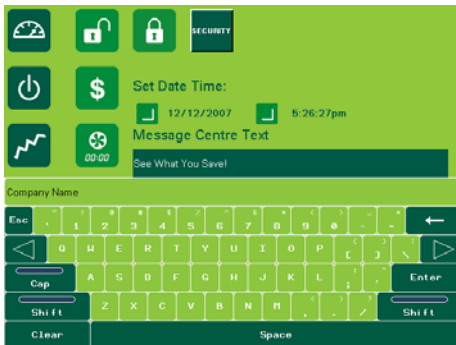

#### Company Name

Company Name

Press the words Company Name to open the Company Name Text keyboard. Using this keyboard enter a kitchen or restaurant name. This is important if the TruFlow will be accessed through the internet. This name will help distinguish one TruFlow panel from another run by the same organization. When you have completed the kitchen or restaurant name press Enter

### Secondary Setup Button



Press the Secondary Setup button to view the kitchen room temperature, the outdoor air temperature and the number of kitchens connected to the TruFlow. The TruFlow on the left has two kitchen connected, one called Main and the other called Prep.

Press the Main Kitchen bar to view all fan drives connected to the main kitchen.





Press the Prep Kitchen bar to view all fan drives connected to the prep kitchen fan drives.

### Viewing Drive Parameters

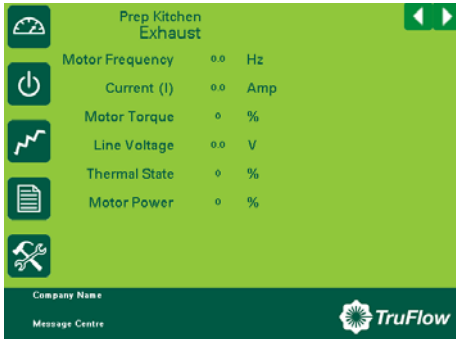

After pressing the Main Kitchen and/or Prep Kitchen bar the drive parameters can be viewed for that specific kitchen.

The user can not change any parameters. The user can view Motor Frequency, Current, Motor Torque, Line Voltage, Thermal State, and Motor Power.

In the example on the left the Prep Kitchen has two exhaust fans. Exhaust is first exhaust fan parameters.

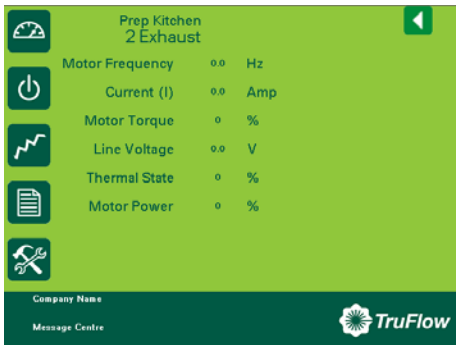

Press the Right Arrow icon at the top right of the screen to view the second exhaust fan parameters. (2Exhaust)



Press the Left Arrow key once to return to the first exhaust fan parameters.

Press the Left Arrow key again to return to the Secondary Setup Screen.

### Changing the Kitchen Names:



User must first Login to the TruFlow. On this TruFlow there are two kitchens operating: Kitchen 1 and Kitchen 2.

Press the Kitchen 1 box to change the screen to the efficiency graph screen.

### Kitchen 1 efficiency graph screen

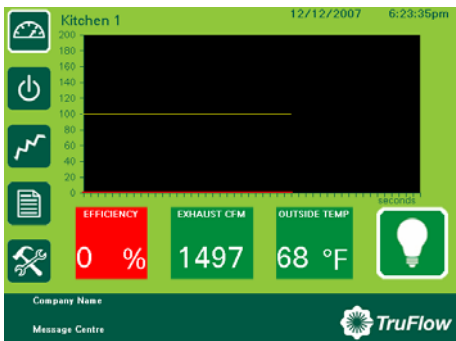

Press the Kitchen 1 word at the top left of the screen



The TruFlow keyboard appears. Type the name of the kitchen using up to 10 characters. Press the enter key when you are done. Return to the Dashbord and press the Kitchen 2 box to change the screen to the Kitchen 2 efficiency graph. Repeat as above.

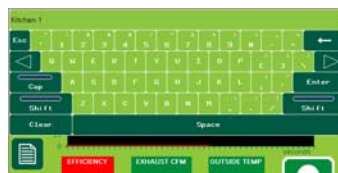

## The Diagnostic Screen



From the Dashboard press the Diagnostic button. The Diagnostic screen includes a record of all faults during the operation of the TruFlow.



Acknowledge All Faults button



Acknowledge Fault button



Scroll Up one line



Scroll Down one line



Scroll Up one page



Scroll Down one page



Run diagnostic script when available.

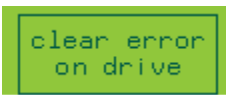

Clear Com or Comport error.

### Errors



When an error occurs the screen will change to red with a yellow exclamation mark.

Touch the screen anywhere and the diagnostic screen appears.

The screen displays the latest error message including the date, time, state and whether the error has been acknowledged. Most errors are self explanatory.



Press this button for additional explanation. When available a popup screen appears with additional information.

Whenever there is a COMM PORT or COMM error or fault, the Clear Error On Drive button must be pressed after the faults has been corrected to resume normal operation.

## The Report Screen

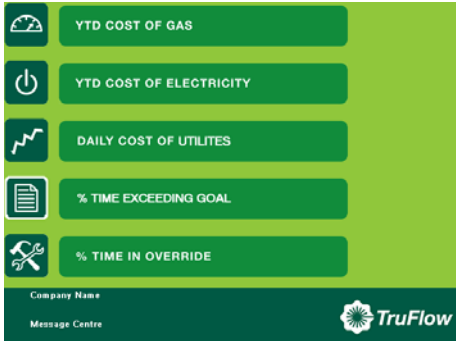

From the Dashboard press the Report button.

The reports available are listed on the screen. Press any bar to view the reports named.

### YTD Cost of Gas

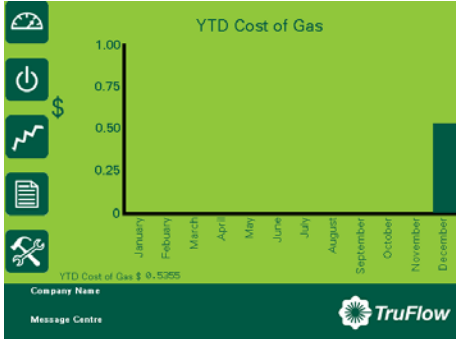

#### YTD COST OF GAS

The YTD Cost of Gas report is a chart of the cost of gas in dollars vs the month of the year for all kitchens connected to TruFlow. The first month of the year is the month the TruFlow was commissioned. The cost of gas includes the cost to heat the kitchen makeup air unit that is replacing the kitchen exhaust during winter operation.

YTD Cost of Gas \$ 0.5945

The yearly accumulative gas cost is shown just above the Company Name on the lower left side of the chart.

### YTD Cost of Electricity

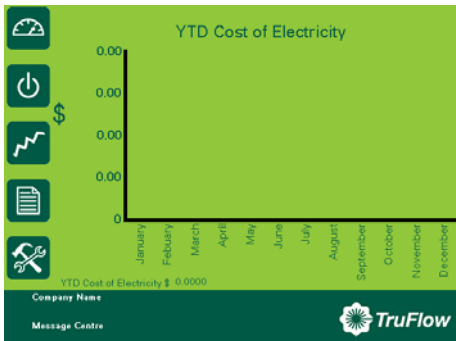

#### YTD COST OF ELECTRICITY

The YTD Cost of Electricity report is a chart of the cost of electricity in dollars vs the month of the year for all kitchens connected to TruFlow. The first month of the year is the month the TruFlow was commissioned. The electricity cost includes the cost to run any motor connected to the TruFlow and the cost to air condition the kitchen during the summer from a DX or chilled water makeup air unit.

YTD Cost of Electricity \$ 0.0000

The yearly accumulative electrical cost is shown just above the Company Name on the lower left side of the chart.

### Daily Cost of Utilities

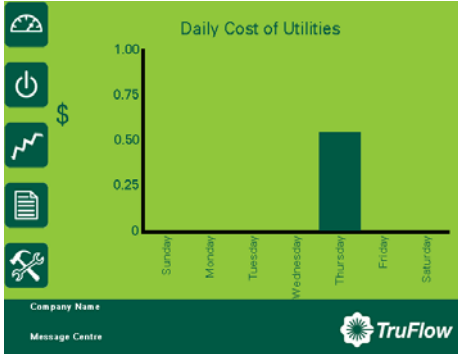

### DAILY COST OF UTILITES

The Daily Cost of Utilities report is a chart of the daily cost of gas and electricity in dollars vs the day of the week for all kitchens connected to TruFlow. The first day of the week is the day the TruFlow was commissioned. The electricity cost includes the cost to run any motor connected to the TruFlow and the cost to air condition the kitchen during the summer from a DX or chilled water makeup air unit.. The cost of gas includes the cost to heat the kitchen makeup air unit that is replacing the kitchen exhaust during winter operation.

### % Time in Override



### % TIME IN OVERRIDE

The % Time in Override graph plots the percentage of time in override vs the total time of operation. If the percentage time in override exceeds 20% call an authorized Spring Air Systems service technician to adjust the TruFlow Override Sensitivity range with the TruFlow.

### % Time Exceeding Goal



### % TIME EXCEEDING GOAL

The % Time Exceeding goal graph plots the percentage of time you have exceeded your goal vs the total time of operation. If the value is above zero you are exceeding your annual goal reduction.

# MXFLOW OPTION

## INCREASING FILTER LIFE

MXFLOW is designed to increase filter life while maintaining maximum exhaust volume during the commercial kitchen cooking operation. Immediately after commissioning the KES unit the exhaust air volume is at the highest level. As each of the three filter banks captures grease particulate of micron and submicron size they begin to fill and the air resistance through each filter increases. Even though the KESF unit has a heavy duty, Class II, backward inclined fan the increase in combined resistance (static pressure “W.C.”) through each filter will gradually reduce the exhaust volume. In cases where there is very heavy cooking with large quantities of micron and submicron grease particulate the reduced exhaust volume is most noticeable. In some cases the filters may have to be changed not because the filter is clogged but because the combined static pressure resistance through all the filters has reduced the exhaust volume enough to affect smoke capture. This is less of a problem with lighter cooking operations.

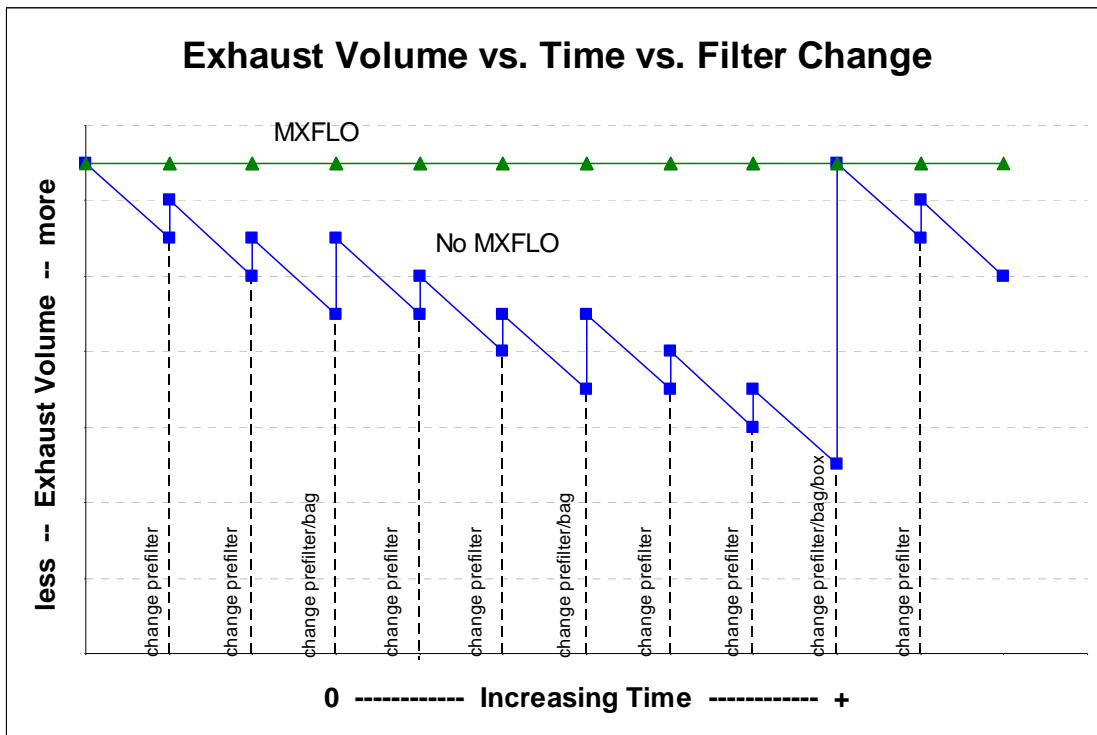

Figure 24

In the example above the “No MXFLOW” KES unit exhaust volume (shown in BLUE) gradually drops as the filters become increasingly clogged. Even when the prefilterers and bag filters are replaced the exhaust volume does not return to maximum because the box filter continues to clog. This drop in exhaust volume generally only represents about 10% of the total exhaust volume. But in some cases this can be enough to affect the hoods ability to capture smoke adequately.

The “MXFLOW” KES unit incorporates a combination pressure transducer/PLC and variable speed drive to maintain constant exhaust volume regardless of the increased static pressure through any of the particulate filters. As the pressure across any filter increases and the exhaust volume decreases the pressure transducer/PLC senses this change and automatically increases the exhaust fan speed to compensate for this increased static pressure to maintain a constant exhaust volume.

MAXFLOW also allows for one touch exhaust volume adjustment when commissioning the unit; thereby making commissioning a more straightforward process. Additionally, MAXFLOW eliminated the need to change sheaves. If the exhaust volume has to be field adjusted because of an appliance change or ductwork change the MXFLO provides automatic exhaust volume adjustment, up or down, from a the microprocessor screen.

### **MAXFLOW Components**

The MAXFLOW is factory installed and tested prior to shipment. The components consist of the MXFLOW control panel model LV10 in conjunction with a exhaust fan motor variable speed controller.

The MXFLOW components are located in the LV10 panel. The MXFLOW components include the pressure transducer (PT), and micro-processor (DMP). When the operator turns on the KESF exhaust fan the motor starts. In addition a 24V power supply activates both the digital readout on the micro-processor and the PT. The (+ve) pressure port on the PT is vented to atmosphere and the (-ve) pressure port is piped into the inlet of the KES-ISH filter box. The probes measure the external static pressure on the inlet of the KES-ISH filter box. The DMP is factory set to the filter box inlet static pressure as indicated on the KES LV10 drawing. The PT is located in the LV10 panel with the pressure probes existing from the top. One probe enters the unit casing and the other is vented to atmosphere.

### **Operation**

As a filter clogs, the pressure drop through the filter increases, decreasing the exhaust air volume, and decreasing the static pressure measured at the PT. The PT sends a signal to the DMP to increase the static pressure back to the set point by increasing fan speed. The result is a constant exhaust volume until the filters are full and must be replaced.

### **CHECKING FAN ROTATION**

Fan rotation should be checked prior to commission the system. The backward inclined KESF fan must be running backwards such that the fan blades pushing the air from the back of the blade. If the fan is scooping the air change the fan rotation. To correct fan rotation switch two of the high voltage wires on terminals V/T1, U/T2 or W/T3 on the drive or switch two wires at the motor.

**SHUT OF ALL POWER TO THE KESF BEFORE CORRECTING ROTATION**



*A KESF DWDI fan. Correct rotation for this fan arrangement looking into the end shown above is clockwise  
Figure 25*

## CHANGING EXHAUST AIR VOLUME ON SITE

With the MXFLOW system changing the exhaust air volume on site is a simple and easy task. First complete the startup report attached in the back of this manual. Once the report has been completed and the system is operating satisfactory measure the actual exhaust air volume using the appropriate air flow measuring device.

The exhaust air volume can be adjusted approximately +/- 15% from the factory setting with the touch of a button.

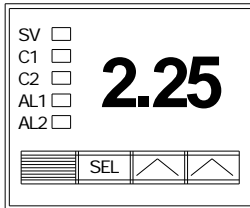

To adjust the exhaust volume, press the SEL. The SV lamp is on. To increase the exhaust volume adjust the static pressure set point up with the ^ button. To decrease the exhaust volume, adjust the static pressure set point down with the v button. The rule of them is approximately 0.5 increase or decrease to change the exhaust volume by 5%. This is only a rule of thumb. After the adjustment the exhaust volume must be measured again. After three seconds the DMP will operate at the new SV setting.

## ODOR SPRAY SYSTEM

### Odor Spray Unit (Optional)



When the Spring Air Systems Enviro (KES) unit has an optional Odor Spray unit mounted on the KESF fan section or in the ductwork, this box will appear on the top left of the Enviro status screen. Press the green box to set the Odor Spray timers.



The Odor Spray has two timers: Cycle Timer and Duration Timer. The Cycle Timer is the time in minutes between spraying. The Duration Timer is the time in seconds of the actual spray.

Press the Cycle Timer box to open the TruFlow number keypad. Select the desired length of the Cycle timer and press Enter to return to the Odor Spray timer screen.

*Enviro odor spray cycle and duration timers.  
Figure 26*

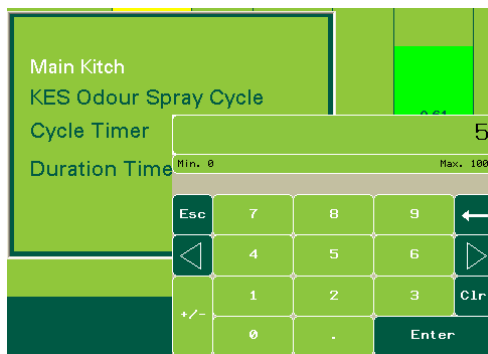

Press the Duration Timer box to open the TruFlow number keypad. Select the desired length of the Duration timer and press Enter to return to the Odor Spray timer screen.

*Setting odor spray Cycle timer*

## How does it Work?

The odor spray setting is a qualitative measurement. The spray timers are field set to provide adequate odor reduction for the installation. This is completely subject to what a particular person feel is an acceptable discharge odor.

During the spray timer activation the combination air compressor and air-atomizing nozzle injects a volume of odor solution into the exhaust discharge. This solution is carried along the discharge duct and vented to atmosphere. The spray solution chemically activates with the kitchen exhaust air to reduce the kitchen exhaust odors. As the solution is carried down the duct some adheres to the duct walls. We will call this the spray residue. During the cycle time when the spray is not activated this spray residue continues the odor reducing process as the exhaust air passes. Therefore installation with longer discharge ducts can normally use a longer cycle time because there will be more spray residue. A shorter run of discharge duct usually results in shorter cycle time.

- A. When adjusting the timers the object is to use as little spray solution as possible to provide adequate odor reduction:
1. First adjust the spray cycle timer.
  2. Reduce this setting by  $\frac{1}{2}$  of the original cycle setting and check the operation. If  $\frac{1}{2}$  proves adequate, increase the cycle back to  $\frac{3}{4}$  of the original cycle setting. If this is adequate increase to  $\frac{7}{8}$  of the original setting and so forth.
  3. If reducing the setting by  $\frac{1}{2}$  is not adequate decrease the cycle to  $\frac{1}{4}$  of the original setting. If this is not adequate adjust the spray timer.
    - a. Increase the spray time in increments of 5 seconds. After each 5 second increase evaluate the quality of the exhaust discharge air to determine if it is acceptable to the user.
    - b. When the spray timer setting equals the cycle timer settings the spray will be continuous. The maximum setting of B02 should not exceed the cycle timer.

The odor spray bottle must be changed regularly depending on the length of time set on the timers. The odor spray line from the spray bottle to the spray nozzle must be cleaned every 6 months in a water and detergent mixture. The compressed air gauge should read between 10 and 15 psi. When the air gauge is reading below 10 psi clean out the compressed air line. If the pressure is still low proceed to the next step compressor maintenance.

## When there is odor in adjoining floors or office spaces

A kitchen located in the interior of an office building must be very negative to keep the kitchen odor within the kitchen. We recommend the kitchen be a minimum 20% negative. The fresh air supply is 80% of the total exhaust air from the kitchen space. When there is odor in adjoining spaces check the following.

1. The kitchen is not negative enough to keep the smell of the kitchen in the kitchen. If this is the case the odor is usually present all the time, even when there is no cooking. Reduce the amount of fresh air to the kitchen by adjusting the supply fan volume.
2. The kitchen may be connected to the same building A/C unit as the rest of the floor. If this is the case the return air grilles in the kitchen draws the kitchen odor to the main A/C unit and disperses the odor throughout the floor. The main A/C return must be blocked from the kitchen and put on a separate A/C unit.
3. The floor above the kitchen have odor. There are three possibilities.
  - a. The exhaust shaft is not sealed and the kitchen exhaust is leaking out onto the floors above the kitchen. Either adjust the amount of odor spray per section "A" above or install an exhaust fan on the roof to draw the kitchen exhaust to the roof and maintain a negative pressure in the discharge duct.
  - b. The odor may escape when the kitchen is not operating during the night. After the kitchen is shut off kitchen odor may migrate up the exhaust duct and leak out into the adjoining floors. This can be solved by operating the kitchen exhaust for a couple hours after the cooking has stopped for the day and starting the kitchen exhaust fan an hour before cooking starts in the morning.

## Odor Spray Compressor Maintenance

Do not, at any time lubricate any of the parts with oil, grease, or petroleum products nor clean with acids, caustics or chlorinated solvents. Be very careful to keep the diaphragm from contacting any petroleum product of hydrocarbons. It can affect the service life of the pump.



To clean or replace the filters and/or rubber gasket, remove the five screws in the top of the unit. The filters and gaskets are located beneath this top plate. Remove the filters and wash then in a solvent and/or blow off with air and replace. The gasket may be cleaned with water. Replace the filters in proper position and replace the gasket. Note that the gasket and top plate will fit in one position only.

To replace the diaphragm, remove the socket cap screws from the head of the pump. The diaphragm is held in place by two Philip head screws. Remove screws, retainer plate, and diaphragm. The diaphragm will fit in any position on the connecting rod. Replace the plate and the two Phillips head screws. Torque to 30 inch-pounds on DOA and DAA.

**Caution:** Do not raise any burrs or nicks on the heads of these screws. These burrs could cause damage to the inlet valve.

For replacing the inlet and outlet valve, remove the slotted machine screw that holds each valve in place. The stainless steel inlet and outlet valves are interchangeable. Clean them with water. When replacing the outlet valve, place the new valve in location and note there is a retaining bar near the machine screw hole. This retaining bar holds the valve in position. When replacing the inlet valve, note that the valve holder is marked with an X in one corner. This X should be in the lower right hand corner toward the inlet of the air chamber. Replace the head and tighten the socket head screws to 90-100 inch-pounds or torque on DOA and DAA.

**WARNING -**  
*The motor is thermally protected and can automatically restart when the protector resets. ALWAYS disconnect KES fan power source before servicing.*

Do not attempt to replace the connecting rod or motor bearings. If after cleaning the unit and/or installing a new service kit, the unit still does not operate properly, contact your representative, the factory, or return the pump to one of our authorized Service Centers.

*IF YOUR PUMP IS EQUIPPED WITH PLASTIC PLUGS IN THE EXHAUST AND/OR INTAKE POTS, REMOVE BEFORE STARTING THE UNIT*

**Wiring Information**

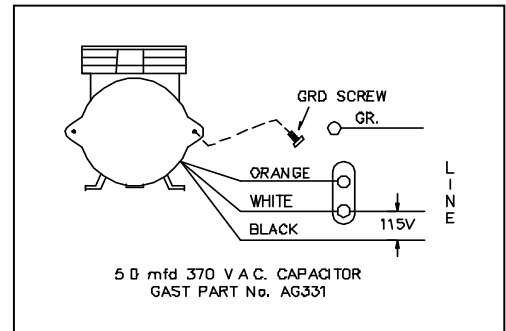
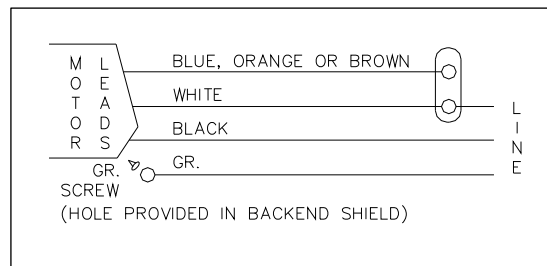

For any permanent split capacitor motor, which has four (4) leads is as follows:  
 Brown leads to capacitor. Black-leads to Power Source.

For any permanent split capacitor for DOA & DAA motor, which has three (3) leads is as follows:

**IMPORTANT NOTICE:**

*DO NOT AT ANY TIME ATTEMPT TO REMOVE THE CONNECTING ROD OR COMPLETELY DISASSEMBLE THE PUMP. IF IT DOES NOT GIVE YOU THE PROPER SERVICE EVEN AFTER INSTALLING A NEW SERVICE KIT, PLEASE RETURN IT TO ONE OF THE AUTHORIZED SERVICE CENTERS*

## WHERE TO PURCHASE FILTERS:

### Spring Air Systems Inc.

1388 Cornwall Rd., Oakville Ont., L6J 7W5  
(905) 338-2999

### Airguard Industries

125 Buttermill Rd., Concord, Ontario, L4K 3X5  
905-669-9876

### Airguard Corp.

4806 Strong Rd., Crystal Lake, IL, 60014  
888-324-5665

### Camfil Farr Filters

67 Steelecase Rd. W., Markham Ont., L3R 2M4  
(905) 415-3030

### Camfil Farr

2201 Park Place, El Segundo, CA, 90245  
310-727-6300

### RECOMMENDATION

*TO ENSURE TROUBLE FREE OPERATION FOR YOUR KITCHEN EXHAUST SYSTEM A PROPER PREVENTATIVE MAINTENANCE PROGRAM IS A NECESSITY.*

*SPRING AIR SYSTEMS RECOMMENDS THAT A YEARLY SERVICE CONTRACT BE SET UP WITH A REPUTABLE SERVICE ORGANIZATION. THIS WILL REDUCE UNEXPECTED DOWN TIME TO A MINIMUM.*

## REPLACEMENT FILTER EQUIVALENTS

### PREFILTERS: MERV7 (30% ASHRAE 52-76) - ULC Class II

Airguard: 24" x 24" x 2" - DP40 Class II  
12" x 24" x 2" - DP40 Class II

American Air Filter:

24" x 24" x 2" - AM-AIR Class II  
12" x 24" x 2" - AM-AIR Class II

Farr Filters: 24" x 24" x 2" - 30% ASHRAE 52-76 Class II  
12" x 24" x 2" - 30% ASHRAE 52-76 Class II

### BAG FILTERS: MERV13 (90 - 95% ASHRAE 52 - 76) - ULC Class II

Airguard: 24" x 24" x 22" - V9-4M Class II  
12" x 24" x 22" - V9-4M Class II

American Air Filter:

24" x 24" x 21" - DRI-PAK - Class II  
12" x 24" x 21" - DRI-PAK - Class II

Farr Filters: 24" x 24" x 22" - 90% ASHRAE 52-76 Class II  
12" x 24" x 22" - 90% ASHRAE 52-76 Class II

### BOX FILTERS: MERV16 (95% DOP/99% ASHRAE 52-76) ULC Class II

Airguard: 24" x 24" x 12" - VMB- 904 Class II  
12" x 24" x 12" - VMB-904 Class II

American Air Filter:

24" x 24" x 12" - BIOCELL Class II  
12" x 24" x 12" - BIOCELL Class II

Farr Filter:

24" x 24" x 12" - 6 pocket - 95% DOP Class II  
12" x 24" x 12" - 6 pocket - 95% DOP Class II

### ODOR MEDIA: 1/8" Activated alumina pellets impregnated with potassium permanganate.

Airguard: Barneby-Cheney CP-2

American Air Filter:

Permasorb

Farr Filters: Unisorb.

**Odor Spray:** Spring Fresh, Spring Air Systems

## WHEN TO CHANGE THE KES FILTERS

The Prefilter, Bag filter and Box filter must be changed on a regular basis to maintain the high grease extraction efficiency required by the UL/ULC listing. Once a red filter clogged light comes on the filter has reached its grease holding capacity. Further use will restrict exhaust air flow causing hood smoke capture problems and/or cause the clogged filter to blow out into the next filter or the exhaust fan. Therefore the three particulate filters must be changed when the red Filter Clogged lights activates. This will provide simple uninterrupted operation for your commercial kitchen operation.

### Determine the Filter Change Schedule

When the KES unit is turned over to you by the installing contractor immediately change the Prefilters. The Prefilters will probably be full of construction debris and this debris will effect the initial operation of the unit.

#### PREFILTERS

1. Enter the startup date on the attached FILTER FREQUENCY CHART. This is the date the Prefilters were changed as well.

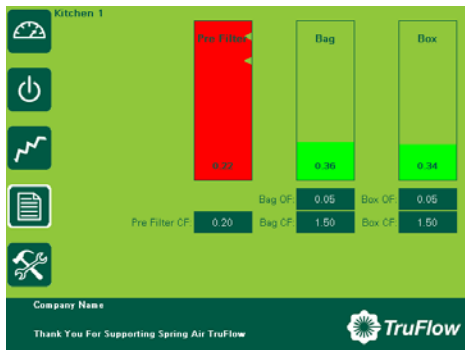

2. Operate the unit until the Prefilter indicator turns red. Change the prefilter at the end of the shift or the next day before cooking. Write

the date that the Prefilters were changed on the FILTER REQUENCY CHART under Filter Change No. 1/Actual.

3. Determine the number of days between the Startup date and the Prefilter Change No. Actual date. Add two days to this number. Add the this number of days to the last actual prefilter change and enter this new prefilter schedule date in the schedule under Filter Change No. 2/Schedule.

*Prefilter Annunciation  
Figure 28*

Change the Prefilters on this new date. If the Filter Clogged alarm annunciates before this new date reduce the number of days to the next scheduled change by one day.

#### BAG FILTERS

1. Operate the unit until the Bag Filter indicator turns red. Change the Bag Filter at the end of the shift or the next day before cooking. Write the date that the Bag Filters were changed on the FILTER REQUENCY CHART under Filter Change No. 1/Actual.
2. Determine the number of days between the Startup date and the Bag Filter Change No. Actual date. Add two days to this number. Add the this number of days to the last actual Bag Filter change and enter this new Bag Filter schedule date in the schedule under Filter Change No. 2/Schedule.

#### BOX FILTERS

1. Operate the unit until the Box Filter indicator turns red. Change the Box Filter at the end of the shift or the next day before cooking. Write the date that the Box Filters were changed on the FILTER REQUENCY CHART under Filter Change No. 1/Actual.
2. Determine the number of days between the Startup date and the Box Filter Change No. Actual date. Add two days to this number. Add the this number of days to the last actual Box Filter change and enter this new Box Filter schedule date in the schedule under Filter Change No. 2/Schedule.

By following the above procedure you will maximize your filter life. Changing the prefilter prior to clogging improves the bag filter life and changing the bag filter prior to clogging improves the box filter life.

**LACK OF EXHAUST VOLUME PRIOR TO SCHEDULED FILTER CHANGE**

When all the filters are clean the exhaust volume is at the maximum. Each of the three filters captures various size grease particulate. The Prefilter capturing the very largest and the Box filter the very smallest. In very heavy applications with large quantities of both micron and submicron particles the exhaust air volume will reduce as the each filters clog. When the loading is very heavy and the MXFLOW FLA have been maximized the FILTER OUT alarm may activate. This means that the exhaust air volume has reduced to a dangerous level. Immediately change the Prefilter(s). If this does not clear the FILTER REMOVED alarm, change the BAG Filter(s). Reschedule the next filter changed based on this new period of time.

Similarly should you experience lack of smoke capture during operation of your hood system prior to a scheduled filter change immediately change the Prefilter. If this does not clear the problem change the BAG Filter. If this does not clear the problem put the old Prefilter and Bag Filters in the unit replace the Box Filter. If this does not clear the problem replace the Prefilter and Bag Filters. Reschedule the next filter changed based on this new period of time.

FILTER FREQUENCY CHART						
Startup date/First Prefilter change						
Change No.	Prefilter		Bag Filter		Box Filter	
	Schedule	Actual	Schedule	Actual	Schedule	Actual
1						
2						
3						
4						
5						
6						
7						
8						
9						
10						
11						
12						
13						
14						
15						
16						
17						
18						
19						
20						
21						
22						
23						
24						

# TROUBLE SHOOTING

## ***I. Low Exhaust Air***

### **1.Exhaust fan is running but exhaust air is low.**

- a)Check if fan belts are slipping. Tighten if necessary.
- b)Check if fusible link fire damper has closed in the KES filter section. Replace fusible link.
- c)Check if filters are dirty but have not alarmed any filter clogged.. Replace dirty filters.
- d)Check for correct fan rotation. On MXFLOW units to correct fan rotation switch two of the high voltage wires on terminals V/T1, U/T2 or W/T3 on the drive or switch two wires at the motor disconnect.

## ***II. Red Filter Clogged Alarm.***

- 1.Filter clogged pilot indicates which filter section has plugged. Replace filter and reset system.
2. If the filter clogged activates earlier then the normal established check the actual operating pressure vs the FILTER CLOGGED pressure setting for each of the filters from the Truflow screen Adjust the pressure setting.
3. If adjusting the pressure switches is not effective and the amount/usage of the kitchen has not increased check the recommended filter clogged limits from the filter manufacturer.

## ***III. Filter Out Alarm.***

1. A filter has been removed or access door left open. Replace if necessary.
2. Check if fusible link fire damper has closed in the KES filter section. Replace fusible link.
3. Check if filters are dirty but have not alarmed any filter clogged.. Replace dirty filters.

## ***V. High Temperature Alarm.***

- 1.The high temperature stat in the KES filter section exhaust outlet has activated and shut the KES system down. If a high temperature is not present check calibration of high temperature stat TH1. High temperature stat is set at 160F.
- 2.Check if fusible link fire damper has closed in the KES filter section. Replace fusible link.

### **Common TruFlow Error (fault) Messages**

- a) Drive(x) Motor Overload/Over-speed fault. Motor overload setting incorrect or RPM too high.
- b) Drive(x) Exhaust over-current fault. Running motor amp too high.
- c) Drive(x) Impending Short Circuit. Possible dead short at fan(x) motor soon.
- d) Drive(x) Motor short circuit fault to earth. Dead short at fan(x) motor
- e) Drive(x) Line supply over-voltage fault. Input voltage source to drive too high.
- f) Drive(x) Line under-voltage fault. Input voltage source to drive too low.
- g) Drive(x) Supply phase loss fault. Input voltage source to drive has lost a phase.
- h) Drive(x) Drive over-heating fault. Drive(x) is overheating. Shut off fan.
- i) Drive(x) Internal Fault. Drive(x) has internal fault that will not allow drive(x) to operate from Touchscreen panel.
- j) Drive(x) Modbus Communication fault. Drive(x) connected to the TruFlow is not communicating with TruFlow.
- k) Drive(x) External Fault. Drive(x) is faulty.
- l) Drive(x) Brake control fault. Possible exhaust fan problem.
- m) Drive(x) Drive voltage disabled. Not input voltage source to Drive(x).
- n) Drive(x) Drive configuration invalid. Drive(x) has lost factory drive configuration.
- o) Surface Fire. The surface fire suppression system has activated.

- p) COMM(x) Fault: Drive(x) has no communication. Drive(x) CAT5 is probably connected to TruFlow.
- q) COMM2 Port Error: The CAT5 to all drives is not connected to the TruFlow
- r) J-Couple Cable Trouble: The J-couples are not connected to the TruFlow.

**Drive Faults and Errors:**

- a) Drive in SLF state: Drive(x) is not communicating with the TruFlow.
- b) Drive in NST state: Drive(x) is communicating but no information is being send by TruFlow.

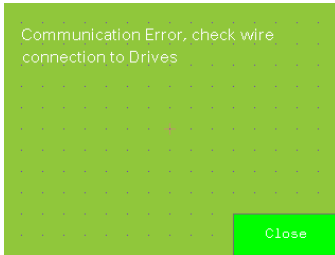

**Typical fault displayed on diagnostic screen after Modbus, Comm Port or Comm fault.**



**Typical fault displayed on Dashboard screen after surface fire suppression activates.**

## KES MAINTENANCE SCHEDULE

### **Every two weeks:**

1. Check the prefilter pressure reading. If the prefilter bar graph is red replace the prefilter. It is very important to maintain clean prefilter(s). Replacing the inexpensive prefilter(s) often extends the life of the bag and box filters and reduces unnecessary down time due to clogged filter shutdowns. *The touchscreen panel will indicate separately when the “prefilter”, “bag” and “box” filters are clogged. When this occurs the unit shuts down. Press the override button to energize the system for another 4 hours. This provides time to change the filters after the day of cooking is complete. This is a final dirty filter alarm after the red dirty filter warning. The filter life of all the filters is constant for each operation. Once the approximate filter life for your application is determined we recommend that a regular filter change schedule be set up before the filter clog activates.*

### **Every Month:**

1. Complete the two-week list.
2. Inspect the exhaust fan belt for correct tension and wear. All belts usually require adjustment at this time. Failure to tighten may result in the belt falling off and no airflow.
3. Check the bag filter (2nd stage filtration) pressure reading. If the bag filter bar graph is red replace the bag filter. The life of the bag filter depends on the type of cooking equipment and exhaust hood system. For heavy cooking applications the bag filters may require replacement every month.
4. **(Odor Spray Option)** Inspect the odor spray bottle. Refill if necessary. *At startup the odor spray is adjusted to the desired level. The amount of odor spray used varies with this initial setting. It is important to inspect the level in the bottle every two weeks until the normal rate of use is determined.*

### **Every Three Months:**

1. Complete the two-week and monthly checklist.
2. Inspect the exhaust fan belt for correct tension and wear. Adjust if necessary.
3. Check the box filter (3rd stage filtration) pressure reading. . If the box filter bar graph is red replace the box filter. Once again the life of the box filter depends on the type of cooking equipment and exhaust hood system. The box filter may provide one year of service on most applications with high efficiency water wash ventilators.
4. Inspect all electrical connections. Tighten if necessary.
5. Test the filter-removed circuit. Open the prefilter access door while the KES unit is in operation. The unit should shut down and indicate a filter-removed condition.

### **Every Six Months:**

1. Complete the two-week, monthly and three month check list.
2. Open the fan wheel access door or hatch on the KES fan section. Inspect the fan wheel for grease build up. Clean as required.
3. Inspect the exhaust inlet fire damper and fusible link. Replace link annually.
4. Check the motor and fan bearings for noise or overheating. STY and FYC bearings are factory pre-lubricated lifetime sealed and require no further lubrication. SY and FY bearings are pre-lubricated and equipped with pressure grease fittings for re-greasing. Under normal service conditions grease after six months of operation.
5. (Odor Pellet Option) Inspect the condition of odor media.
6. *The odor media pellets can be checked for remaining life by sending a sample to an accredited test laboratory. Most major filter suppliers have access to such service. Replace media if required. To replace the media remove the cells from the KES unit. Open the side panel on each odor cell and pour out the used media. Refill the cells with new media. Shake cells while filling to allow pellets to settle evenly in the cell. **Note:** Do not allow odor media to come in contact with water, as this will immediately render the pellets useless.*

### **Every Year:**

1. Complete the two-week, monthly, three month and six month check list.
2. Check if KESF fan motor is running hotter than normal. If the motor running hot check the operating AMPS of the motor.
3. Make sure the KESF fan wheel rotates freely before startup. Inspect and clean the wheel periodically. If dirt is allowed to build up the wheel could become out of balance and cause premature bearing wear.

### **Fan Bearings**

1. STY and FYC bearings are factory pre-lubricated lifetime sealed and require no further lubrication.
2. SY and FY bearings are pre-lubricated and equipped with pressure grease fittings for re-greasing.
3. Under normal service conditions grease after six months of operation.

### **Motor Bearings:**

1. All motors leave the factory with bearings custom greased for many years of service under most conditions.
2. Re-greasing of motors depends on the application and is best left to trained service technicians.
3. Periodically check if motor is running hotter than normal.

### **Centrifugal Exhaust Fan:**

1. Make sure the wheel rotates freely before startup.
2. Inspect and clean the wheel periodically.
3. If dirt is allowed to build up the wheel could become out of balance and cause premature bearing wear.
4. A noisy fan is a typical sign of a fan out of balance.



**V-Belt Drives:**

- 1.ALWAYS KEEP SPARE SET OF BELTS. Periodically check the belt tension and adjust if necessary.
- 2.Some slack should be left in the belt, typically 1/4" per foot of belt from the fan to the motor sheave.
- 3.Always replace the complete set of belts to ensure even tension and wear. When replacing belts loosen the motor mounts.
- 4.Do not force belts over sheaves.

**RECOMMENDATION**

TO ENSURE TROUBLE FREE OPERATION FOR YOUR KITCHEN EXHAUST SYSTEM A PROPER PREVENTATIVE MAINTENANCE PROGRAM IS NECESSARY. SPRING AIR RECOMMENDS THAT A YEARLY SERVICE CONTRACT BE SET UP WITH A REPUTABLE SERVICE ORGANIZATION. THIS WILL REDUCE UNEXPECTED DOWN TIME TO A MINIMUM.

# APPENDIX

## A. TRUFLOW ONLY:

### SETTING THE DMP (PXR) Controller for Pressure Transducer

	<b>Set Point (SV parameter) - Setting the set point</b>
SV=total static pressure	Press SEL once. Use V and Λ to adjust the project set point. Press SEL. The factory setting is the total static pressure indicated on the KESF unit drawings" W.C. (Total static pressure)

### PXR3 Micro-controller: Factory setup

Power the MXFLOW panel and proceed to input the following setting.

	<b>2<sup>nd</sup> Block Parameters</b>
	Press SEL and hold for about 3 seconds until P appears on the display. Release SEL.
P=17.3	Press SEL again to set the Proportional Band. Use the Λ to increase parameter set value and V to decrease parameter set value. Set P = 17.3 and then press SEL.
I=12	Press V to next parameter, integral time, I. Press SEL and set value to 12. Press SEL
d=3.3	Press V to next parameter, derivative action time, d. Press SEL and set value to 6.6. Press SEL.
hys=0	Press V to next parameter, hysteresis, hys. Press SEL and set value to 6.6. Press SEL
CTrL=PID	Press V three times to next parameter, Control algorithm, CTrL. Press SEL and check that the setting is PID. If is not us the V and Λ to set to PID and then press SEL.
P-n2=16	Press V three times to next parameter, input type code, P-n2. Press SEL and adjust setting to 16. Press SEL.
P-SL=0	Press V to next parameter, Lower limit of input range, P-SL. Press SEL and adjust setting to 0. Press SEL.
P-SU=500	Press V to next parameter, Upper limit of input range, P-SU. Press SEL and adjust setting to 10. Press SEL.
p-dP=2	Press SEL and hold for about 2 seconds to return to set point.



	<b>3<sup>rd</sup> Block Parameters</b>
	Press SEL and hold for about 5 seconds until P-n1 appears on the display. Release SEL.
P-n1=1	Press SEL again to set the Control Action, P-n1. Use the Λ and V to adjust the value to 3. Press SEL.
SV-L=0	Press V to next parameter, Lower limit of SV, SV-L. Press SEL and adjust setting to 0. Press SEL.
SV-H=5	Press V to next parameter, Upper limit of SV, SV-H. Press SEL and adjust setting to 8. Press SEL.
	Press SEL and hold for about 2 seconds to return to set point.

	<b>1st Block Parameters</b>
	Press SEL and hold for about 1 second until STbY appears on the display. (or LACH)
AT=1	<b>AUTOTUNING</b> Press V until AT appears on display. Press SEL and set the Auto-tuning to 1. using V and Λ. Press SEL.
LOC	Locks the parameter values

After re-programming any value **Autotune** the controller again.

## [8] Sensor fault operation

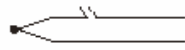
### • Thermocouple

Condition		Display	Control output
Break		<b>UUUUU</b>	ON or more than 20mA (Note) OFF or less than 4mA
Short circuit		short-circuit point Temperature display	Input is controlled as short-circuit point temperature. (Note)

### • 4-20mA DC

Over-range	<b>UUUUU</b>	OFF or less than 4mA (Note)
Under-range	<b>LLLLL</b>	ON or more than 20mA

## B. TRUFLOW ONLY: FACTORY DRIVE TERMINAL SCHEMATIC

Wiring Diagram for Factory Settings

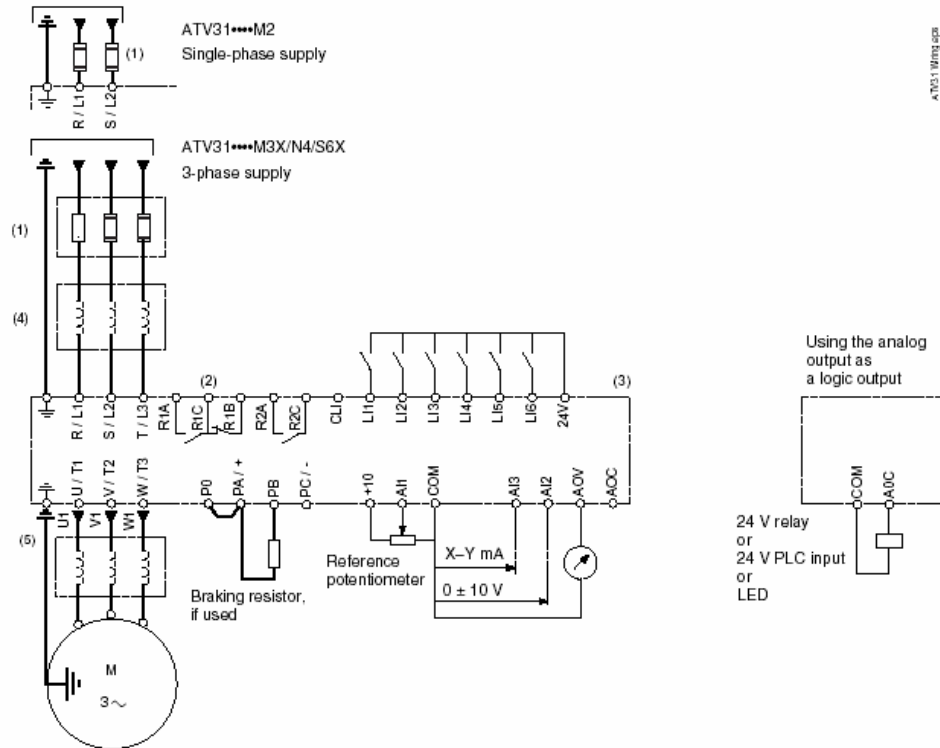

*NOTE: The line supply terminals are shown at the top and the motor terminals are shown at the bottom. Connect the power terminals before connecting the control terminals. Install surge suppressors on all inductive circuits located near the drive controller or coupled to the same circuit.*

- (1) Refer to the drive controller nameplate or to the tables on pages 34–35 for recommended fuses. Fast acting or time delay Class J fuses can be used.
- (2) Fault relay contacts for remote indication of drive controller status.
- (3) Internal +24 V. If an external source is used (30 V max.), connect the 0 V terminal of the source to the 0 V (COM) terminal, and do not use the +24 V terminal on the drive controller for any purpose.
- (4) Line reactor, if used. All 575 V installations must include a line reactor. See page 21.
- (5) Installation of a load filter is recommended for all 575 V applications. See page 22.

## LOGIC INPUT SWITCH

The logic input switch assigns the logic input common link to 0 V (Source logic), 24 V (Sink logic), or floating.

*NOTE: When the logic input is configured for Sink logic, grounding the input signals can result in unintended activation of drive controller functions.*

**⚠ DANGER**

**UNINTENDED EQUIPMENT OPERATION**

- Protect the signal conductors against damage that could result in unintentional conductor grounding.
- Follow NFPA 79 and EN 60204 guidelines for proper control circuit grounding practices.

**Failure to follow these instructions can result in death, serious injury, or equipment damage.**

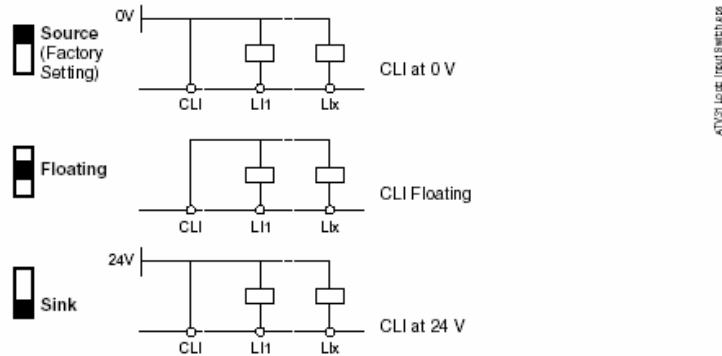

## DRIVE TECHNICAL SPECIFICATIONS FOR LOCATING DRIVE PANELS

**Table 2: Environment**

Degree of Protection	<ul style="list-style-type: none"> <li>• IP20 without protective vent cover, NEMA 1, UL open type.</li> <li>• IP21 on wiring terminals</li> <li>• IP31 and IP41 all other areas</li> <li>• UL Type 1 without removal of the protective vent cover from the top of the controller and with the addition of the Conduit Entry Kit (see page 14).</li> </ul>
Resistance to vibrations	Conforming to IEC/EN 60068-2-6: 1.5 mm peak to peak from 3 to 13 Hz, 1 gn from 13 to 150 Hz
Resistance to shocks	15 gn for 11 ms conforming to IEC/EN 60068-2-27
Pollution degree	Pollution degree 2 according to UL 840. Protect the drive controller against dust, corrosive gas, and falling liquid.
Maximum relative humidity	96% maximum, non-condensing and without dripping (provide heating system if there is condensation) Conforms to IEC 60068-2-3
Maximum ambient temperature	Storage: -13 to +158 °F (-25 to +70 °C) Operation: +14 to +122 °F (-10 to +50 °C) without vent cover removed and without derating +14 to +140 °F (-10 to +60 °C) with vent cover removed and with derating. Refer to derating curves on page 15.
Altitude	Up to 3,300 ft (1,000 m) without derating; derate by 1% for each additional 330 ft (100 m)

## C. HAZARDOUS WARNING

**⚠ DANGER**

**HAZARDOUS VOLTAGE**

- Read and understand this manual before installing or operating the Altivar 31 drive controller. Installation, adjustment, repair, and maintenance must be performed by qualified personnel.
- For more information on Altivar 31 drive controllers, see the *Altivar 31 Start-Up Guide*, VVDED303043US, and the *Altivar 31 Programming Manual*, VVDED303042US. Both manuals are shipped with the drive controller. They are also available from [www.us.SquareD.com](http://www.us.SquareD.com) or from your Schneider Electric representative.
- The user is responsible for conforming to all applicable code requirements with respect to grounding all equipment.
- Many parts in this drive controller, including printed wiring boards, operate at line voltage. **DO NOT TOUCH.** Use only electrically insulated tools.
- **DO NOT** touch unshielded components or terminal strip screw connections with voltage present.
- **DO NOT** short across terminals PA and PC or across the DC bus capacitors.
- Install and close all covers before applying power or starting and stopping the drive controller.
- Before servicing the drive controller:
  - Disconnect all power.
  - Place a "DO NOT TURN ON" label on the drive controller disconnect.
  - Lock the disconnect in the open position.
- Disconnect all power including external control power that may be present before servicing the drive controller. **WAIT 3 MINUTES** for the DC bus capacitors to discharge. Then follow the DC bus voltage measurement procedure on page 20 to verify that the DC voltage is less than 45 Vdc. The drive controller LEDs are not accurate indicators of the absence of DC bus voltage.

**Electric shock will result in death or serious injury.**

## D. TRUFLOW ONLY: GOOD WIRING PRACTICE

Good wiring practice requires the separation of control circuit wiring from all power (line) wiring. In addition, power wiring to the motor must have the maximum possible separation from all other power wiring, whether from the same drive controller or other drive controllers; **do not run in the same conduit**. This separation reduces the possibility of coupling electrical transients from power circuits into control circuits or from motor power wiring into other power circuits.

### **▲ CAUTION**

#### **IMPROPER WIRING PRACTICES**

- Follow the wiring practices described in this document in addition to those already required by the National Electrical Code and local electrical codes.
- The drive controller will be damaged if input line voltage is applied to the output terminals (U, V, W).
- Check the power connections before energizing the drive controller.
- If replacing another drive controller, verify that all wiring connections to the ATV31 drive controller comply with all wiring instructions in this manual.

**Failure to follow this instruction can result in injury or equipment damage.**

Follow the practices below when wiring ATV31 drive controllers:

- Verify that the voltage and frequency of the input supply line and the voltage, frequency, and current of the motor match the rating on the drive controller nameplate.
- Use metallic conduit for all drive controller wiring. Do not run control and power wiring in the same conduit.
- Separate the metallic conduits carrying power wiring from those carrying control wiring by at least 76 mm (3 in.).
- Separate the non-metallic conduits or cable trays used to carry power wiring from the metallic conduit carrying control wiring by at least 305 mm (12 in.).
- Whenever power and control wiring cross, the metallic conduits and non-metallic conduits or trays must cross at right angles.
- Equip all inductive circuits near the drive controller (such as relays, contactors, and solenoid valves) with noise suppressors, or connect them to a separate circuit.

## E. TRUFLOW ONLY: GROUNDING

Ground the drive controller according to the National Electrical Code and all local codes to ensure safe, dependable operation. To ground the drive controller:

- Connect a copper wire from the equipment ground lug or terminal to the power system ground conductor. Size the wire according to the drive controller rating and national and local codes.
- Verify that resistance to ground is one ohm or less. Improper grounding causes intermittent and unreliable operation.

**⚠ DANGER**

**HAZARDOUS VOLTAGE**

Ground equipment using the provided ground connecting point as shown in the figure below. The drive controller panel must be properly grounded before power is applied.

**Electric shock will result in death or serious injury.**

Ground multiple drive controllers as shown in the figure below. Do not loop the ground cables or connect them in series.

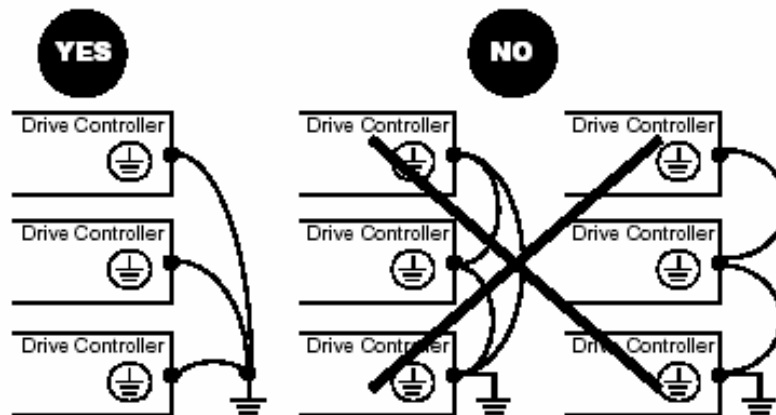



## F. TRUFLOW ONLY: STARTING THE DRIVE

### ATV31\*\*\*\*\* Controllers

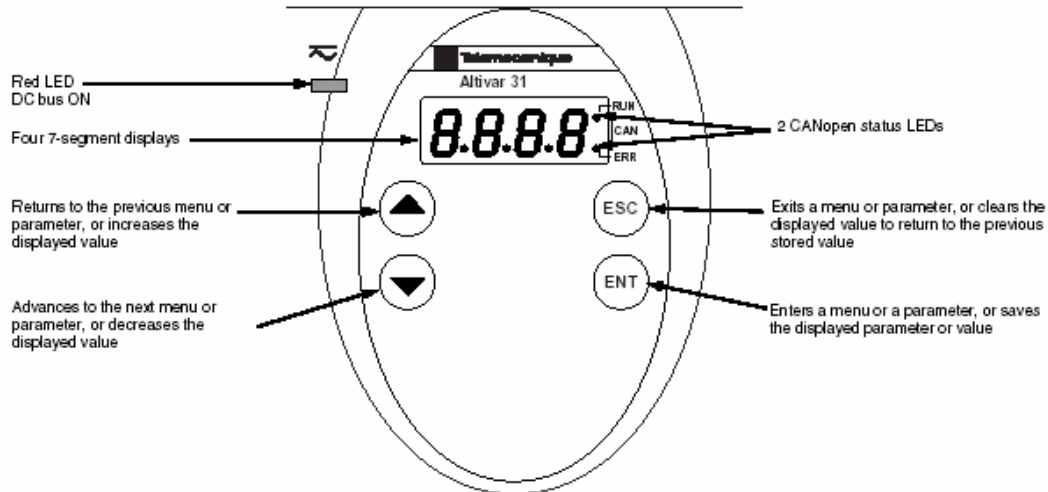

- Press and hold down (longer than 2 seconds) the ▲ or ▼ keys to scroll through the data quickly.
- Pressing ▲ or ▼ does not store the selection.
- To store the selection, press the ENT key. The display flashes when a value is stored.

A normal display with no fault present and no run command shows:

- The value of one of the display parameters (see page 80). The default display is motor frequency, for example 43.0. In current limiting mode, the display flashes.
  - init: Initialization sequence
  - rdY: Drive ready
  - dcb: DC injection braking in progress
  - nSt: Freewheel stop
  - FSt: Fast stop
  - tUn: Auto-tuning in progress
- If a fault is present, the display flashes.

## G. TRUFLOW ONLY: ACCESSING THE DRIVE PROGRAM MENU

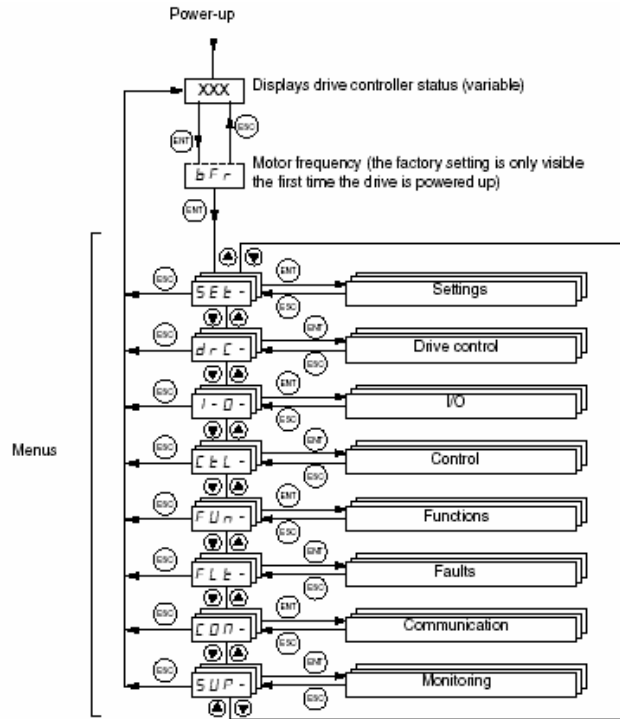

The following figure illustrates how to access parameters and assign their values. To store the parameter value, press the **ENT** key. The display flashes when a value is stored.

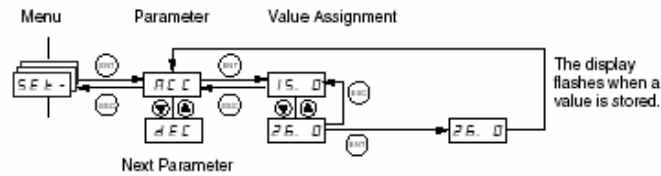

All of the menus are drop-down type menus. Once you have reached the last parameter in a list, press the **▼** key to return to the first parameter. From the first parameter in the list, press the **▲** key to jump to the last parameter.

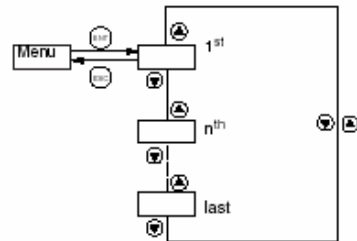

If you have modified a parameter in a menu and you return to that menu without accessing another menu in the meantime, you will be taken directly to the parameter you last modified. See the illustration below. If you have accessed another menu or have restarted the drive controller since the modification, you will be taken to the first parameter in the menu. See the illustration above.















## H. TRUFLOW ONLY PROGRAMMING THE DRIVE PARAMETERS





















### TRUFLOW Parameter Setting on Drive























#### NOTES:





















If blinking **SLF** appears on screen then recycle the power.

Press  to select until the screen blinks. If drive value is already desired value then screen will not blink upon reselection.

1. Press  if **nSt** appears on screen.
2. Press  until **drC-** appears on screen.
3. Press 
4. Press  until **bFr** appears.
5. Press 
6. Press  or  to obtain 60.0.
7. Press 
8. Press 
9. Press  until **nCr** appears on screen.
10. Press 
11. Press  or  until **FLA** appears.
12. Press 
13. Press 

14. Press  until *t F r* appears.
15. Press 
16. Press  or  to obtain 72.0.
17. Press 
18. Press 
19. Press 
20. Press  until *S E t -* appears.
21. Press 
22. Press  until *A C C* appears.
23. Press 
24. Press  or  to obtain 10.0.
25. Press 
26. Press 
27. Press  until *d E C* appears.
28. Press 
29. Press  or  to obtain 10.0.
30. Press 
31. Press 

32. Press  until *LSP* appears.
33. Press 
34. Press  or  to obtain 18.0.
35. Press 
36. Press 
37. Press  until *SP2* appears.
38. Press 
39. Press  or  to obtain 60.0.
40. Press 
41. Press 
42. Press  until *HSP* appears.
43. Press 
44. Press  or  to obtain 60.0.
45. Press 
46. Press 
47. Press  until *t t d* appears.
48. Press 
49. Press  to obtain 118.
50. Press 

51. Press 
52. Press 
53. Press  until **C E L -** appears.
54. Press 
55. Press  until **L A C** appears.
56. Press 
57. Press  or  until **L 3** appears.
58. Press  and HOLD until the screen blinks.
59. Press 
60. Press  until **F r 1** appears.
61. Press 
62. Press  or  until **A 1 1** appears.
63. Press  and HOLD until the screen blinks.
64. Press 
65. Press  until **F r 2** appears.
66. Press 
67. Press  or  until **n d b** appears.
68. Press  and HOLD until the screen blinks. **S L F**

69. WAIT FOR FEW MINUTES UNTIL THE SCREEN BLINKS

70. Press 

71. Press  until **C E L -** appears.

72. Press 

73. Press  until **r F C** appears.

74. Press 

75. Press  or  until **L I S** appears.

76. Press  and HOLD until the screen blinks.

77. Press 

78. Press 

79. Press  until **I - O -** appears.

80. Press 

81. Press  until **E C E** appears.

82. Press 

83. Press  or  until **L E L** appears.























84. Press 





















85. Press 

86. Press 

87. Press  until **F U n -** appears.



88. Press 
89. Press  until **S A 1 -** appears.
90. Press 
91. Press  or  until **S A 2** appears.
92. Press 
93. Press  or  until **n 0** appears.
94. Press 
95. Press 
96. Press  until **S A 3** appears.
97. Press 
98. Press  or  until **n 0** appears.
99. Press 
100. Press 
101. Press 
102. Press 
103. Press  until **F L E -** appears.
104. Press 
105. Press  or  until **A E r** appears.
106. Press 

107. Press  or  until **YES** appears.
108. Press 
109. Press 
110. Press  until **drn** appears.
111. Press 
112. Press  until **YES** appears.
113. Press  and HOLD until screen blinks.
114. Press 
115. Press  until **DPL** appears.
116. Press 
117. Press  or  until **YES** appears.
118. Press 
119. Press 
120. Press 
121. Press  until **CON -** appears.
122. Press 
123. Press  or  until **Add** appears.
124. Press 

125. Press  or  to assign an address to the drive.

*NOTE: IF ONLY ONE FAN IS ASSOCIATED SELECT "2" AND GO TO STEP 126. FOR MULTIPLE MOTORS, CONTACT SPRING AIR TO OBTAIN TRUE ADDRESS FOR A DRIVE.*

126. Press 

127. Press 

128. Press  until *E F 0* appears.

129. Press 



130. Press  or  until *B n 1* appears.

131. Press 

132. Press 

133. Press  until *A d C 0* appears.

134. Press 

135. Press  or  until 0 appears.

136. Press 



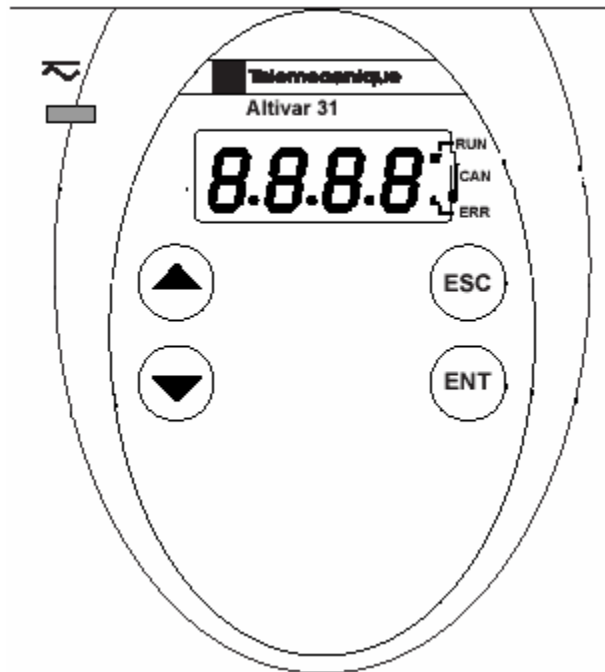

137. Press  until blinking *S L F* appears on screen.

## I. DRIVE FACTORY RESET

### Drive Key Pad Display



**Figure 1** Drive Key Pad Display

-  Scroll up OR increase numerical value
-  Scroll down OR decrease numerical value
-  Explore directory OR Select
-  Exit directory / Go back

## Resetting the Drive to Factory Setting

### Notes:

Ensure that the motor is NOT running while performing this operation.

1) Read the screen.

a. `SLF` then recycle the power

b. `nSt` press 

2) Press  until `dr [-` appears on screen.

3) Press 

4) Press  until `FCS` appears on screen.

5) Press 

6) Press  until `In I` appears on screen.

7) Press  and HOLD until the screen blinks and `n 0` appears.

8) Press  until `nSt` is on screen.

## J. TRUFLOW ONLY: TROUBLE SHOOTING AND DRIVE FAULT DISPLAY

### PRECAUTIONS

Read the following safety statements before proceeding with any maintenance or troubleshooting procedures.

 <b>DANGER</b>
<b>HAZARDOUS VOLTAGE</b> <ul style="list-style-type: none"><li>• Disconnect all power before servicing the drive controller.</li><li>• Read and understand these procedure and the precaution on page 13 of this manual before servicing the ATV31 drive controllers.</li><li>• Installation, adjustment, and maintenance of these drive controllers must be performed by qualified personnel.</li></ul> <p>Failure to follow this instruction will result in death or serious injury.</p>

### ROUTINE MAINTENANCE

Perform the following steps at regular intervals:

- Check the condition and tightness of the connections.
- Make sure that the ventilation is effective and that the temperature around the drive controller remains at an acceptable level.
- Remove dust and debris from the drive controller, if necessary.

### FAULT DISPLAY

If a problem arises during setup or operation, ensure that all ambient environment, mounting, and connection recommendations have been followed.

The first fault detected is stored and displayed, flashing, on the screen. The drive controller locks and the fault relay (RA-RC) contact opens, if it has been configured for this function.

### Drive Controller Does Not Start, No Fault Displayed

If the drive controller will not start and there is no display indication, consider the following:

1. Check the power supply to the drive controller.
2. The assignment of the fast stop or freewheel stop functions prevents the drive controller from starting if the corresponding logic inputs are not powered up. In this case, the drive controller displays nSt in freewheel stop mode and FSt in fast mode. This is normal, since these functions are active at zero speed so that the drive controller will stop safely if there is a wire break.
3. Ensure that the run command inputs have been actuated in accordance with the chosen control mode (ICC parameter in the I-O- menu. See page 29).
4. If an input is assigned to the limit switch function and this input is at state 0, the drive controller can only be started by sending a command for the opposite direction (see page 72).
5. If the reference channel (page 37) or the control channel (page 38) is assigned to Modbus or CANopen, the drive controller displays nSt on power up and remains stopped until the communication bus sends a command.

## TROUBLESHOOTING

### Fault Display

If a problem occurs during setup or operation, ensure that all ambient environment, mounting, and connection recommendations have been followed.

The first fault detected is stored and displayed, flashing, on the screen. The drive controller locks and the fault relay (R1A-R1C or R2A-R2C) contact opens.

### Drive Controller Does Not Start, No Display

If the drive controller will not start and there is no display indication, check the power supply to the drive controller. Refer to the *ATV31 Programming Manual* for more troubleshooting information.

### Faults Which Cannot be Automatically Reset

Faults which cannot be automatically reset are listed in the table beginning on page 44. To clear these faults:

1. Remove power from the drive controller.
2. Wait for the display to go off completely.
3. Determine the cause of the fault and correct it.
4. Reapply power.

CrF, SOF, tnF, bLF, and OPF can also be reset remotely via a logic input (rSF parameter in the FLT- menu, see the *ATV31 Programming Manual*).

### Faults Which Cannot be Automatically Reset

Fault	Probable Cause	Remedy
<i>b L F</i> Brake sequence	Brake release current not reached	<ul style="list-style-type: none"> <li>• Check the drive controller and motor connections.</li> <li>• Check the motor windings.</li> <li>• Check the Ibr setting in the FUn-menu. Refer to the <i>ATV31 Programming Manual</i>.</li> </ul>
<i>C r F</i> Precharge circuit fault	Precharge circuit damaged	<ul style="list-style-type: none"> <li>• Reset the drive controller.</li> <li>• Replace the drive controller.</li> </ul>
<i>I n F</i> Internal fault	<ul style="list-style-type: none"> <li>• Internal fault</li> <li>• Internal connection fault</li> </ul>	<ul style="list-style-type: none"> <li>• Remove sources of electromagnetic interference.</li> <li>• Replace the drive controller.</li> </ul>
<i>O C F</i> Overcurrent	<ul style="list-style-type: none"> <li>• Incorrect parameter settings in the SEt- and drC- menus</li> <li>• Acceleration too rapid</li> <li>• Drive controller and/or motor undersized for load</li> <li>• Mechanical blockage</li> </ul>	<ul style="list-style-type: none"> <li>• Check the SEt- and drC- parameters.</li> <li>• Ensure that the size of the motor and drive controller is sufficient for the load.</li> <li>• Clear the mechanical blockage.</li> </ul>
<i>S C F</i> Motor short circuit	<ul style="list-style-type: none"> <li>• Short circuit or grounding at the drive controller output</li> <li>• Significant ground leakage current at the drive controller output if several motors are connected in parallel</li> </ul>	<ul style="list-style-type: none"> <li>• Check the cables connecting the drive controller to the motor, and check the motor insulation.</li> <li>• Reduce the switching frequency.</li> <li>• Connect output filters in series with the motor.</li> </ul>
<i>S O F</i> Overspeed	<ul style="list-style-type: none"> <li>• Instability</li> <li>• Overhauling load</li> </ul>	<ul style="list-style-type: none"> <li>• Check the motor, gain, and stability parameters.</li> <li>• Add a braking resistor.</li> <li>• Check the size of the motor, drive controller, and load.</li> </ul>
<i>t n F</i> Auto-tuning fault	<ul style="list-style-type: none"> <li>• Motor or motor power not suitable for the drive controller</li> <li>• Motor not connected to the drive controller</li> </ul>	<ul style="list-style-type: none"> <li>• Use the L or the P ratio (see UfT on page 36).</li> <li>• Check the presence of the motor during auto-tuning.</li> <li>• If a downstream contactor is being used, close it during auto-tuning.</li> </ul>



## Faults Which Can be Reset With the Automatic Restart Function

After the cause of the fault has been removed, the following faults can be reset:

- With the automatic restart function (Atr parameter in the FLT- menu, see the *ATV31 Programming Manual*),
- Via a logic input (rSF parameter in the FLT- menu, see the *ATV31 Programming Manual*),
- By cycling power to the drive controller.

## Faults Which Can be Reset With Automatic Restart

Fault	Probable Cause	Remedy
<i>LDL</i> Serial link failure CANopen	Loss of communication between drive controller and communication device or remote keypad.	<ul style="list-style-type: none"> <li>• Check the communication bus.</li> <li>• Refer to the product-specific documentation.</li> </ul>
<i>EPF</i> External fault	User defined	User defined
<i>LLF</i> Loss of 4-20 mA follower	Loss of the 4-20 mA reference on input AI3	Check the connection on input AI3.
<i>ObF</i> Overvoltage during deceleration	<ul style="list-style-type: none"> <li>• Braking too rapidly</li> <li>• Overhauling load</li> </ul>	<ul style="list-style-type: none"> <li>• Increase the deceleration time.</li> <li>• Install a braking resistor if necessary.</li> <li>• Activate the brA function if it is compatible with the application. Refer to the <i>ATV31 Programming Manual</i>.</li> </ul>
<i>OHF</i> Drive overload	<ul style="list-style-type: none"> <li>• Drive controller or ambient temperature are too high.</li> <li>• Continuous motor current load is too high.</li> </ul>	Check the motor load, the drive controller ventilation, and the environment. Wait for the drive controller to cool before restarting.
<i>OLF</i> Motor overload	<ul style="list-style-type: none"> <li>• Thermal trip due to prolonged motor overload</li> <li>• Motor power rating too low for the application</li> </ul>	Check the lth setting (motor thermal protection, page 32), check the motor load. Allow the motor to cool before restarting.

### Faults Which Can be Reset With Automatic Restart (Continued)

Fault	Probable Cause	Remedy
<i>D P F</i> Motor phase failure	<ul style="list-style-type: none"> <li>• Loss of phase at drive controller output</li> <li>• Downstream contactor open</li> <li>• Motor not connected</li> <li>• Instability in the motor current</li> <li>• Drive controller oversized for motor</li> </ul>	<ul style="list-style-type: none"> <li>• Check the connections from the drive controller to the motor.</li> <li>• If a downstream contactor is being used, set OPL to OAC. Refer to the <i>ATV31 Programming Manual</i>, FLT-menu.</li> <li>• Test the drive controller on a low power motor or without a motor: set OPL to nO. Refer to the <i>ATV31 Programming Manual</i>, FLT- menu.</li> <li>• Check and optimize the UFr (page 32), UnS (page 35), and nCr (page 35) parameters and perform auto-tuning (page 36).</li> </ul>
<i>D S F</i> Overvoltage during steady state operation or during acceleration	<ul style="list-style-type: none"> <li>• Line voltage too high</li> <li>• Line supply transients</li> </ul>	<ul style="list-style-type: none"> <li>• Check the line voltage. Compare with the drive controller nameplate rating.</li> <li>• Reset the drive controller.</li> </ul>
<i>P H F</i> Input phase failure	<ul style="list-style-type: none"> <li>• Input phase loss, blown fuse</li> <li>• 3-phase drive controller used on a single phase line supply</li> <li>• Input phase imbalance</li> <li>• Transient phase fault</li> </ul> <p><i>Note: This protection only operates with the drive controller running under load.</i></p>	<ul style="list-style-type: none"> <li>• Check the connections and the fuses.</li> <li>• Disable the fault by setting IPL to nO. Refer to the <i>ATV31 Programming Manual</i>.</li> <li>• Verify that the input power is correct.</li> <li>• Supply 3-phase power if needed.</li> </ul>
<i>S L F</i> Serial link failure Modbus	Loss of connection between drive controller and communication device or remote keypad.	<ul style="list-style-type: none"> <li>• Check the communication connection.</li> <li>• Refer to the product-specific documentation.</li> </ul>



## **L. TRUFLOW INITIAL SETUP**

### **Truflow Factory Setup:**

**Login as Administrator. If you do not have the Administrators password call Spring Air Systems Inc. head office Service Manager.**

Follow the instructions step-by-step in order to complete the initial set up. This set up will allow you to set up the system when it is being installed for the first time.

#### **Important Notes Prior to Touch Screen Setup**

- 1. The circuit breaker is on and providing 120V/1/60.**
- 2. Do not power on the fan(s) prior to the set up.**
- 3. Only administrator can sign in and proceed with the initial set up or make any changes to the system.**
- 4. If the system is being set up for the first time the errors will appear on the screen. Do not attempt to address these errors. Proceed with the initial set up instructions.**
- 5. The commercial kitchen surface fire suppression system has been installed as per NFPA code and tagged.**
- 6. The commercial kitchen exhaust hood(s), exhaust fan(s) and supply fan(s) have been installed in accordance with all applicable national and local codes.**
- 7. All equipments have been installed as per engineering drawings.**
- 8. The interconnection wiring has been installed as per engineering drawings.**
- 9. The interconnection wiring and cables have been installed in accordance with all applicable National and Local Codes.**
- 10. Power up the system. (i.e. PLC, HMI, and Drive)**



3)

Either one of the screen shown below will appear.



OR



4)

Press



Following screen appears.

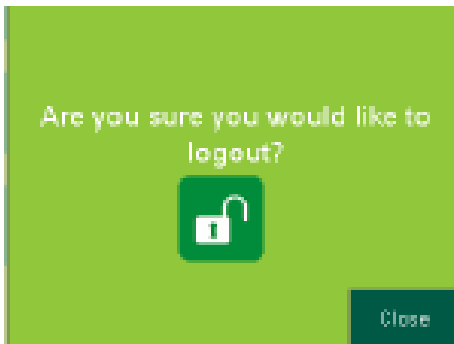

Press



5)

Press



6)

Press



7)

Following screen appears.



8)

Press

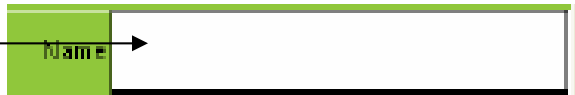

9)

Following screen appears.

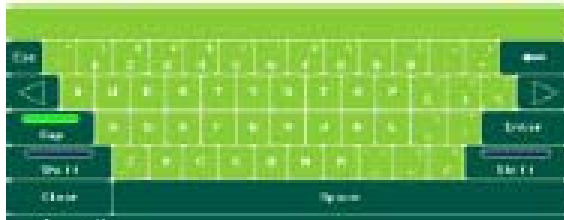

10)

Type your user name using the onscreen keyboard.

NOTE THAT ONLY ADMINISTRATOR WILL HAVE COMPLETE ACCESS TO ALL THE SETUP.

11)

Press



12)

Following screen appears.

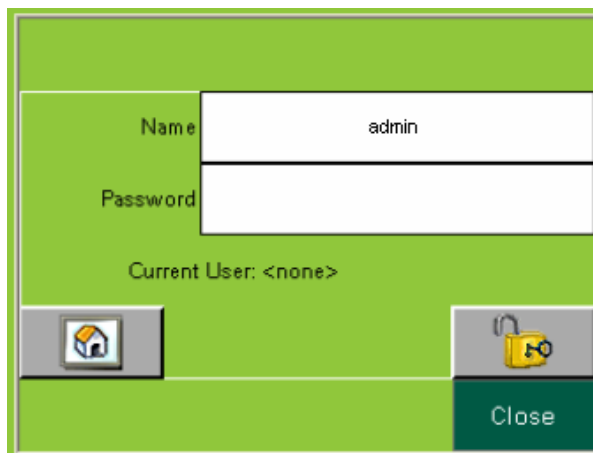

13)

Press

A screenshot of a login interface with a green background. It features two input fields: 'Name' and 'Password'. The 'Name' field contains the text 'admin'. An arrow points from the word 'Press' to the 'Password' field.

14)

Following screen appears.

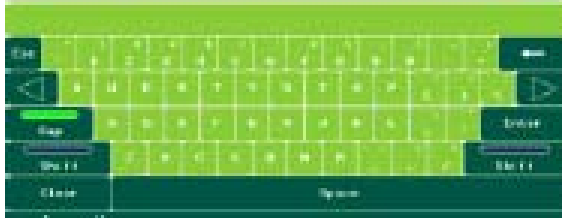

15)

Type your password using on screen keyboard.

16)

Press  (an on screen keyboard key)

17)

Following screen will appear.

A screenshot of the login interface after password entry. The 'Name' field contains 'admin' and the 'Password' field contains '\*\*\*\*\*'. Below the fields, it says 'Current User: <none>'. At the bottom, there are icons for a home screen and a locked padlock, and a 'Close' button.



18)  
Press



Name admin

Password \*\*\*\*\*

Current User: <none>

Close

19)

Following screen will appear on screen.



20)

Press



21)

Following screen will appear.  
NOTE: THIS SCREEN WILL VARY  
DEPENDING ON NUMBER OF  
SYSTEMS.



22)

Press

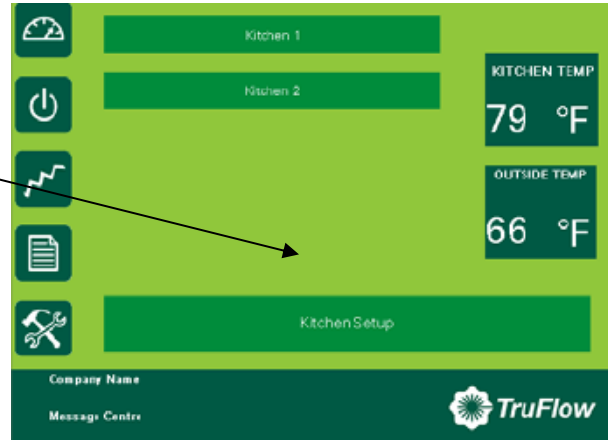

23)

Following screen will appear.



24) CHECK THE SYSTEM CONFIGURATION THEN PROCEED.

a)



Press UP to increase the number of kitchens.



Press DOWN to decrease number of kitchen(s).

b) Press the box beside KES text to select KES unit.



c) Press the box beside RSS to select RSS.



d) Press to select a common make-up air for multiple exhaust fans.



e) Press the box, shown under the *Wash* if the system is connected to spring air water was hood.



f)

If supply fan has Variable Speed drive (VSD), press



Changes to



25)

Press



on top right corner.

26)  
Press Kitchen 1.

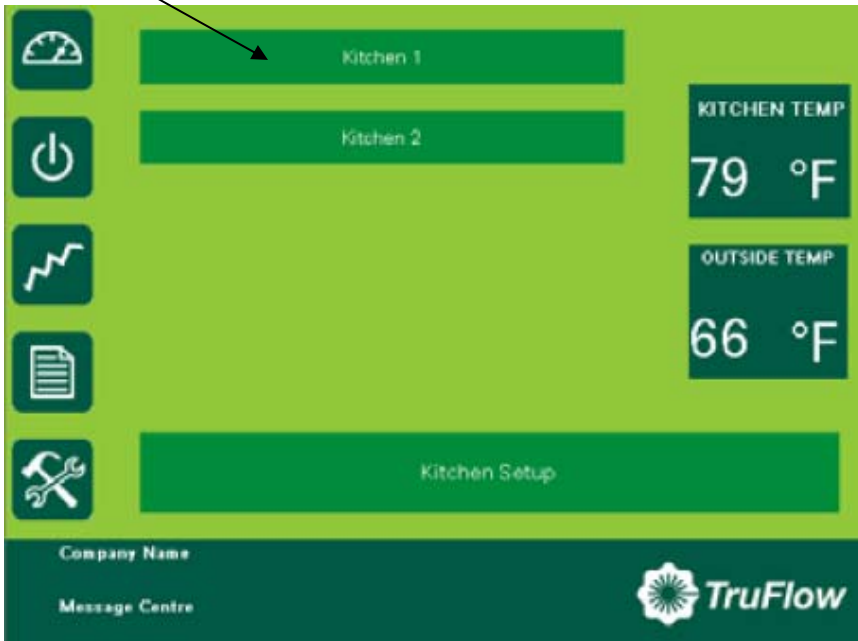

27)  
Following screen will appear.



28)

a)

Press the "READ SPEED" icon for Min Freq.

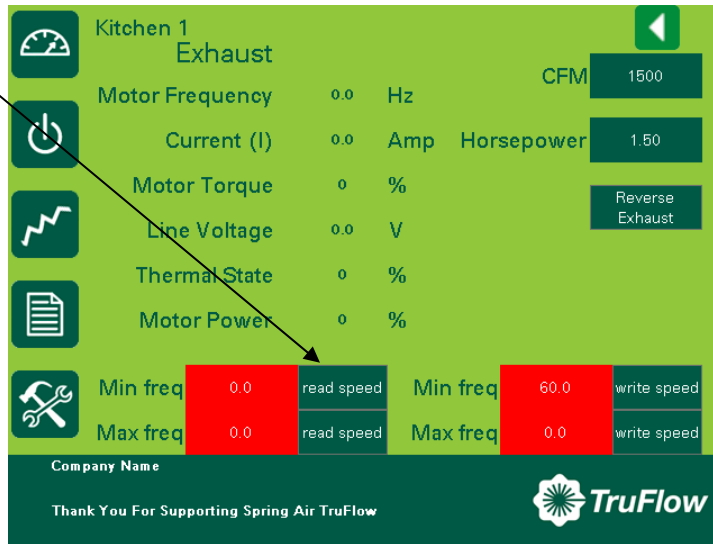

NOTE: IF THE READ VALUE IS NOT 18.0 THEN FOLLOW WRITE FREQUENCY SHOWN AT THE END.

b)

The icon turns pink. Please WAIT until the pink icon turns back green.

c)

Press "READ SPEED" icon for Max Freq.

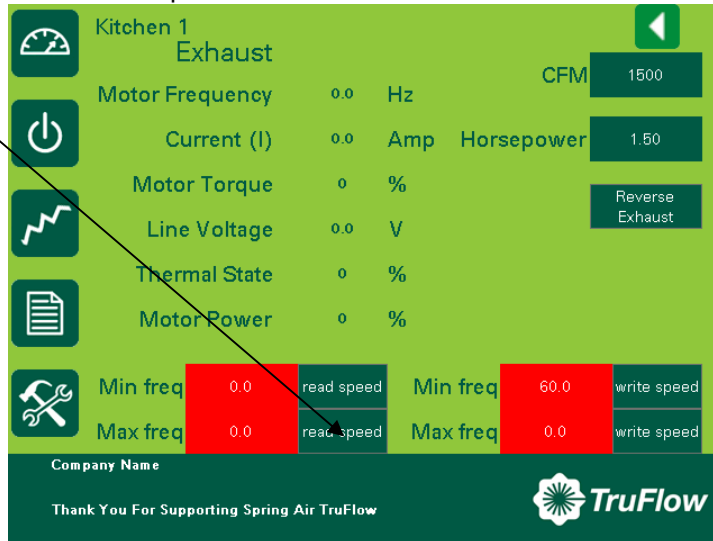

NOTE: IF THE READ VALUE IS NOT 65.0 THEN FOLLOW WRITE FREQUENCY SHOWN AT THE END.

c)  
Press the box beside CFM.

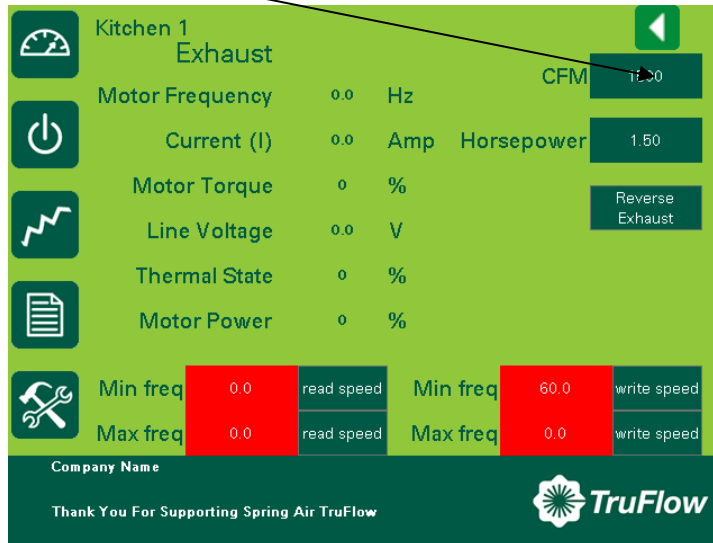

d)  
Following window with a key pad appears.

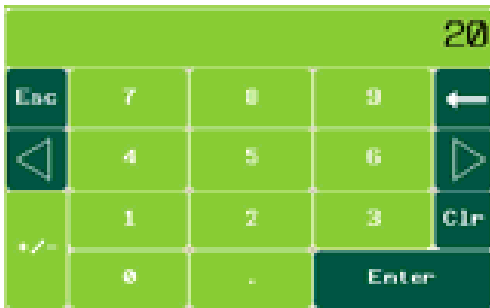

e)  
Type the exhaust CFM for the selected Kitchen and

Press 

f) Press the box beside horsepower.

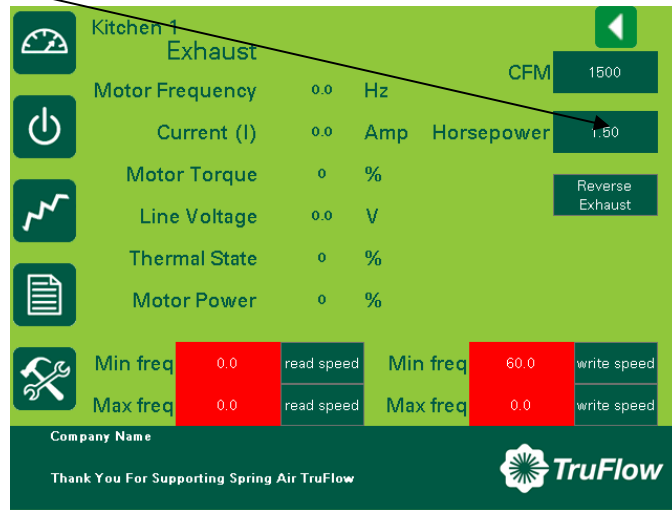

g) Following screen with a key pad appears on screen.

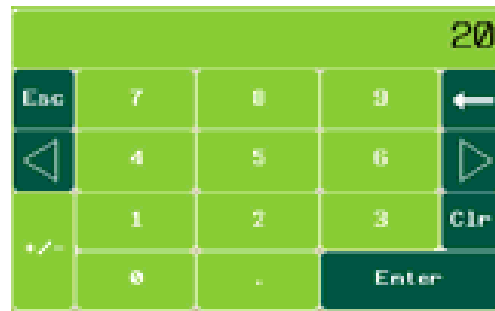

h) Type horsepower for the selected motor and

Press 

i) Press  at top right corner.

j) If more than one kitchen is installed, then repeat step 24 to 26(a-i) for the rest of the kitchens.

k) Press 

29)

Press



30)

Following window will appear.



31)

a)

Press the box under "Reduction Goal (%)"



b)

Following screen will appear.

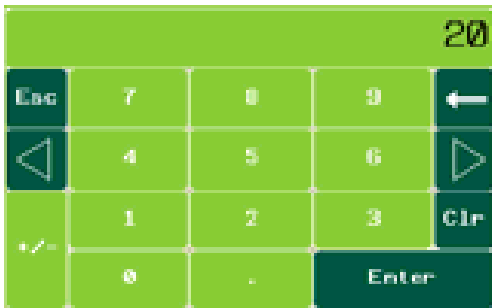

c)

Assign a value. If the value is not known, press "Enter".



d)  
Press the box under the "Gas Cost".



e)  
The following screen will appear.



f)  
Assign the cost. If the cost is not known, press "Enter".

g)  
Press the box under the "Electricity Cost."



**h)**  
Following Screen will appear.



**i)**  
Assign cost and press "Enter". If the cost is not known, press "Enter".

**32)**



**33)**

Following screen will appear.

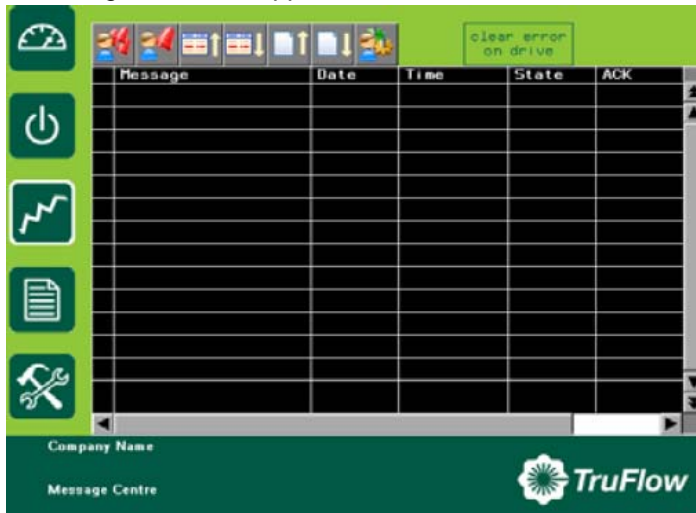

34)

a)

Press and HOLD “clear errors on drive” for 5 seconds to clear the errors.



b)

If the “comm. 2 error” appears then recycle the power and repeat all the steps again.

c)

If no error pops up, then go to **Step 33**.

35)

Press



36)

Following screen will appear.



**NOTE: THIS SCREEN WILL VARY DEPENDING ON THE NUMBER OF SYSTEMS (KITCHENS) ARE DESIGNED.**

37)

Press



38) The system should start up.

## Override Drive Frequency (Read and Write)

1) Follow steps 1-18.

2) Press 

3) Press 

4) Press

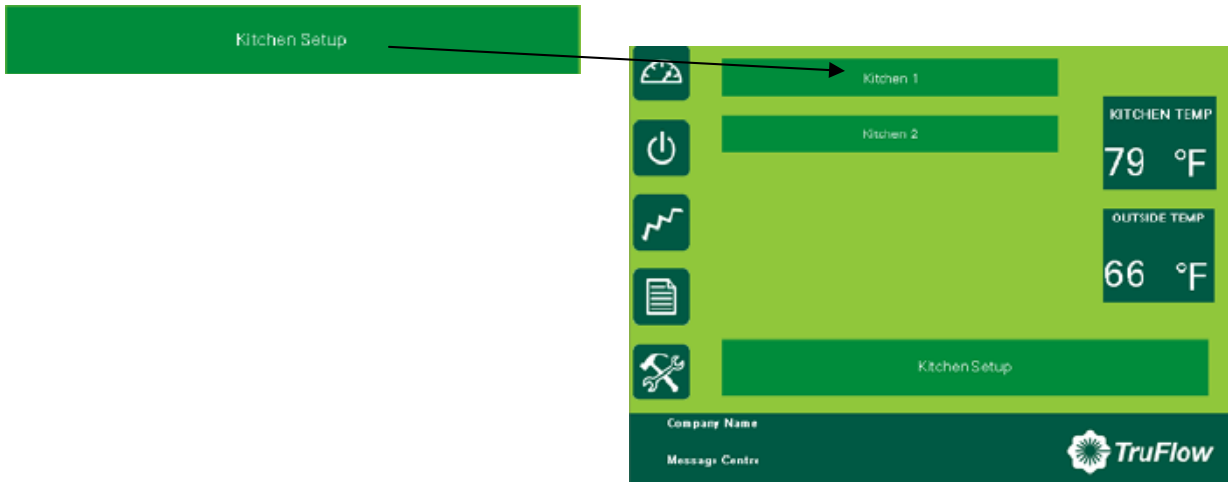

5) Press on the text box between *Min freq* and *write speed*.

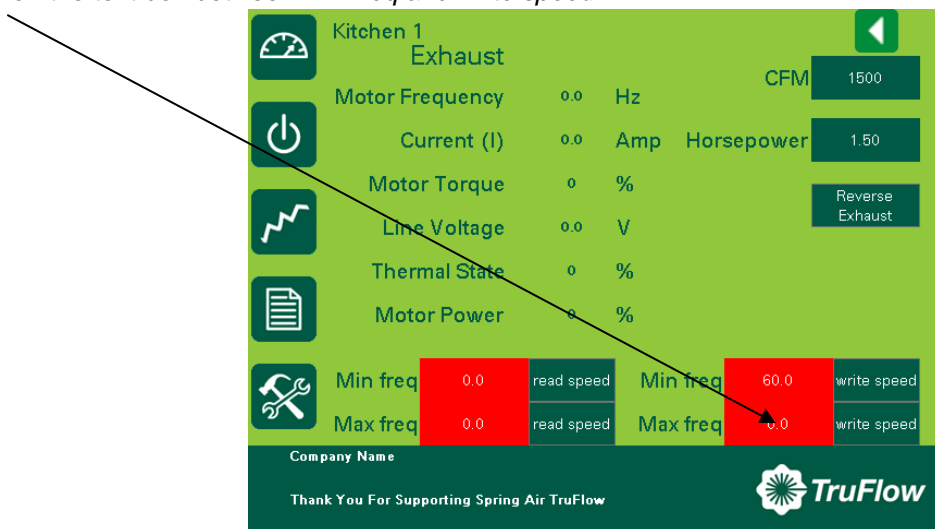

6)

Following keypad appears.

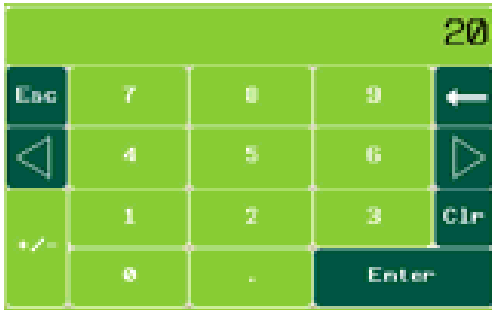

7)

Assign a frequency and

Press



8)

Press

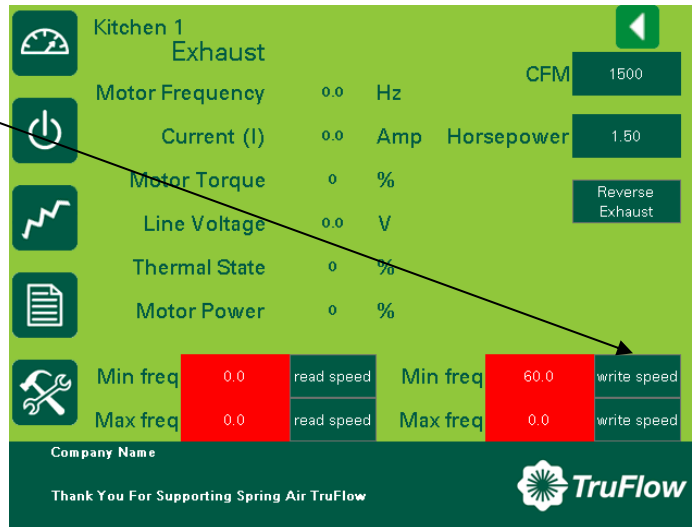

9)

The icon turns pink WAIT until the icon turns back green.

10)

To confirm whether the value has been assigned

Press

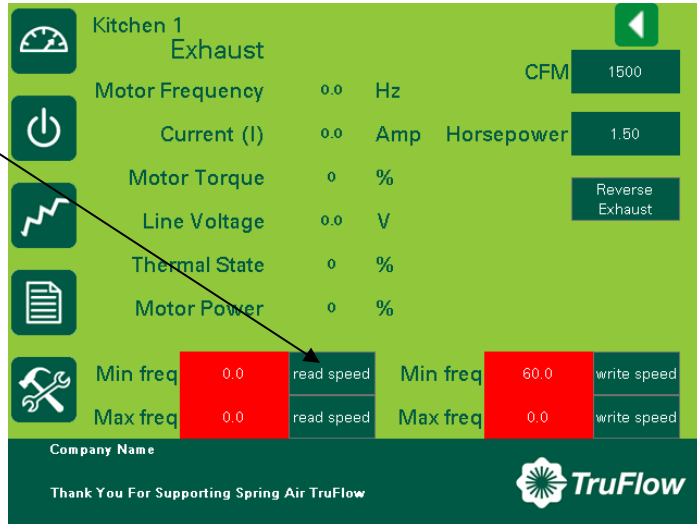

11)

Confirm the value

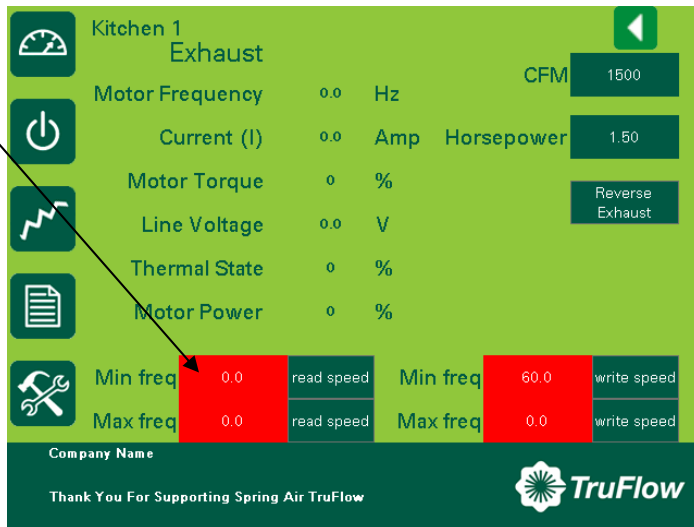

12)  
To write Max freq,  
Press the text box between *Max freq* and *write speed*.

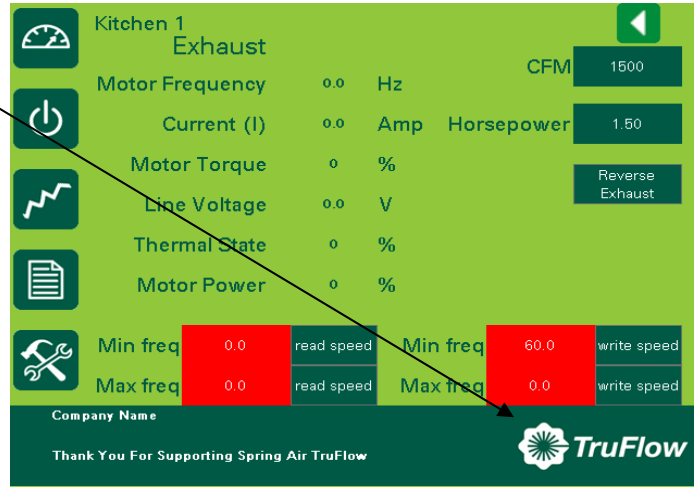

13)  
A keypad appears on the screen.



14)  
Type desired frequency and

Press 

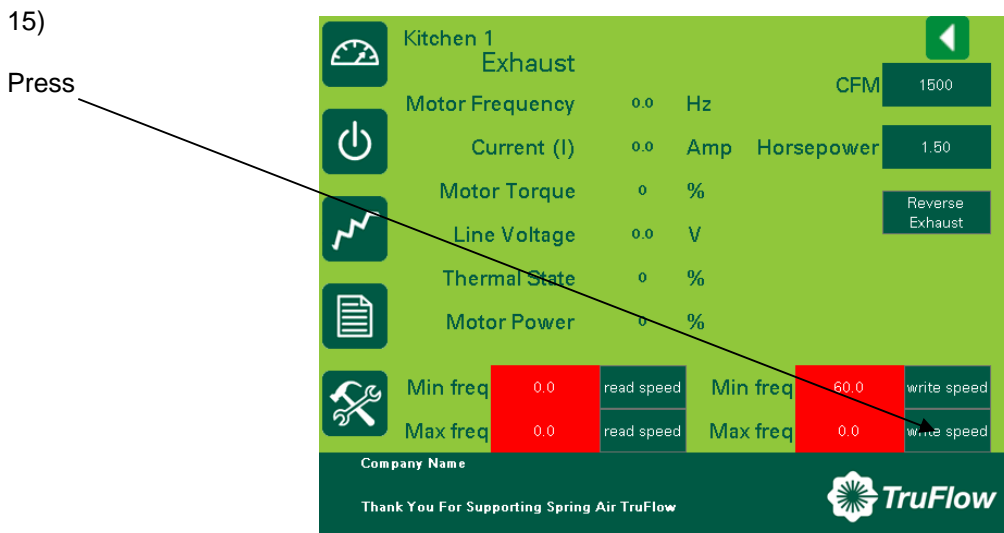

16)

The icon turns pink WAIT until the icon turns back green.

17)

To confirm whether the value has been assigned

Press

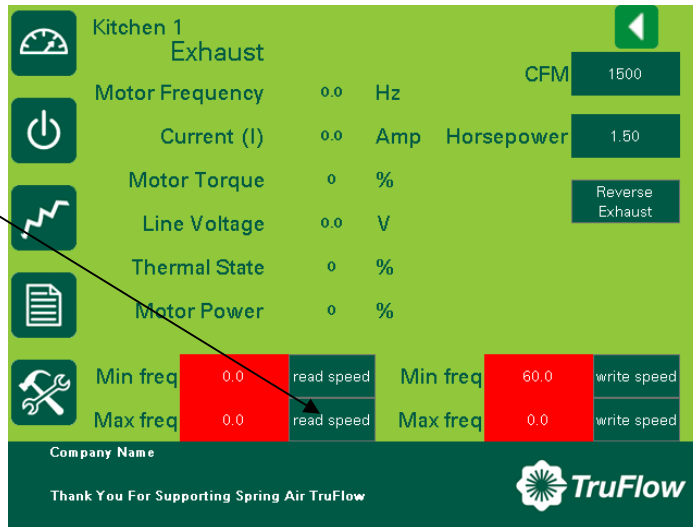

18)

Entered value should appear.

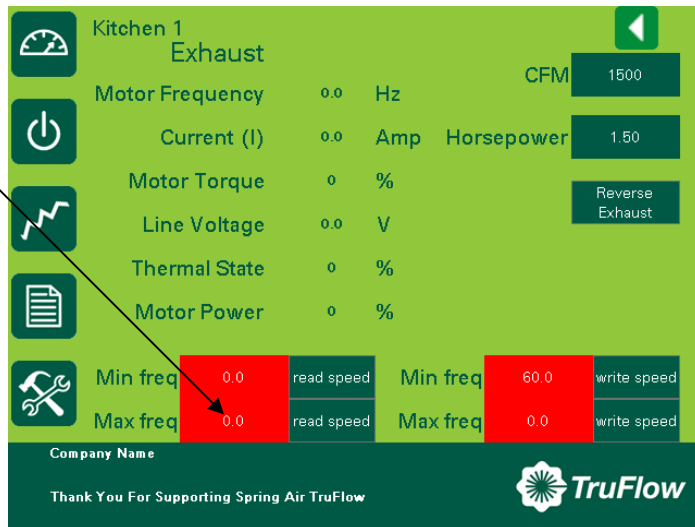



# M. LV10 FACTORY WIRING

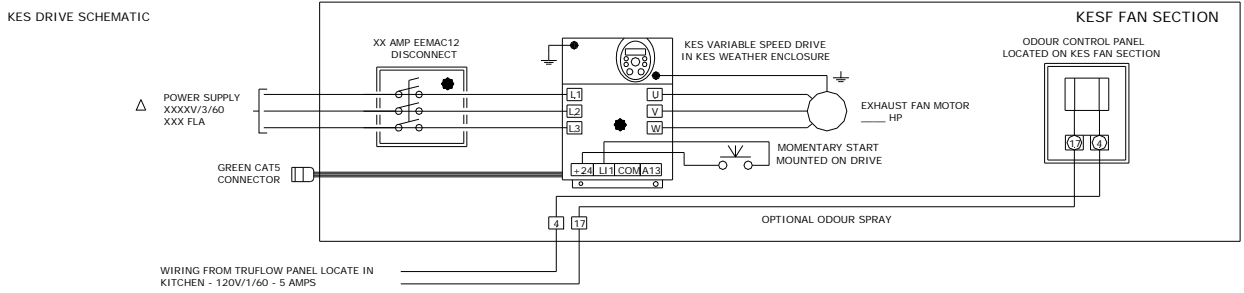

**LV10 TRUFLOW TRANSDUCER SCHEMATIC**

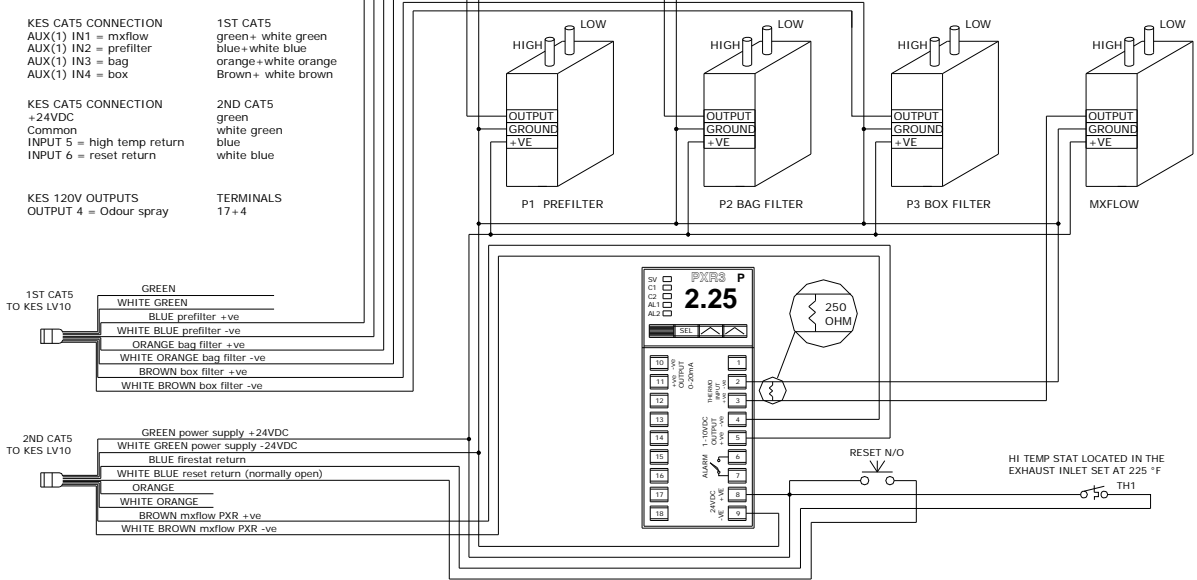

*Other Fine Products From*

## ***SPRING AIR SYSTEMS...***

- Water Wash Ventilators
  - ◆ Hot Water Wash
  - ◆ Cold Water Spray/Hot Water Wash
  - ◆ Water Wash Control Panels
- Dry Extractor Hoods
- ***REV-LOW*** Hoods
- Cartridge Hoods
- Filter Hoods
- Surface Fire Suppression
- Commercial Kitchen Exhaust Fans
- Kitchen Enviro Systems
  - ◆ KES - 100% Exhaust
- Commercial Kitchen Supply Units
- Compensating Hoods
- Exhaust Fans
- Supply Fans
- Commercial Kitchen Control Panels
- Variable Speed Exhaust/Supply Systems

Phone: 905-338-2999, FAX: 905-338-1079, e-mail [info@springairsystems.com](mailto:info@springairsystems.com)  
[www.springairsystems.com](http://www.springairsystems.com)